



model 3377G

ADA Vandal-Resistant Outdoor Steel Pedestal Fountain

FEATURES & BENEFITS

CONSTRUCTION

Heavy duty 3/16" (.47 cm) galvanized steel pedestal is supported by an integral mounting plate

BARRIER-FREE

Barrier-free capabilities combined with its ease of use allows for a number of installation location possibilities.

GALVANIZED FINISH

Tough galvanized coating is ideal for areas where rusting is an issue, and vandalism and graffiti could be present. Due to the galvanizing process, appearance will be a rough, unfinished galvanized surface.

BUBBLER HEAD

Polished chrome-plated brass bubbler head with integral laminar flow prevents splashing while providing a superior flow pattern. The integral 1 1/16" dia. basin shank and stainless anti-rotation roll pin for vandal resistance strength. Shielded, angled stream opening provides a steady source of drinking water at .45 gpm.

DRINKING FOUNTAIN VALVE

The push-button activated valve offers the only all stainless steel valve body that is machined out of solid bar stock, is fully serviceable through the front of the push button assembly offering access to the water control cartridge and integral water supply strainer, and with front access to the water stream height adjustment for easy maintenance without having to remove the valve. Operating pressure range of 30 to 90 psi (2.1 to 6.2 bar).

VANDAL-RESISTANT

The bubbler head, push button, round bowl, drain strainer and bottom plate are locked in place, discouraging unwanted vandal tampering.



SPECIFICATIONS

Model 3377G ADA vandal-resistant pedestal drinking fountain shall include a 14 gauge Type 304 Stainless Steel satin finish bracket, 18 gauge Type 304 Stainless Steel satin finish basin with integral swirl design, 100% lead-free waterways, vandal-resistant push-button operated stainless steel valve with front-accessible cartridge and flow adjustment, polished chrome-plated brass vandal-resistant bubbler head with integral laminar anti-squirt flow, chrome-plated brass vandal-resistant waste strainer, vandal-resistant bottom plate, 3/16" (.47 cm) rough unfinished galvanized surface top-access pedestal, integral mounting plate, and 1-1/4" IPS waste.

APPLICATIONS

Perfect for either public or private outdoor settings, the 3377G is a great fit in areas where aesthetics are important to the overall appeal of the architecture. Suitable in areas where weather conditions exist, this series stands strong as a nice addition to any community. Galvanized finish help to maintain the fountains overall appeal so it remains looking as new as it did when it was installed. This type of pedestal drinking fountain may also be placed in a variety of settings such as: parks, schools, and other outdoor environments around office buildings where the temperature remains above freezing. Model meets all current Federal Regulations for the disabled including those in the Americans with Disabilities Act. Haws manufactures drinking fountains, faucets and electric water coolers to be lead-free by all known definitions including NSF/ANSI/CAN 61-Section 9, NSF/ANSI/CAN 372, California Proposition 65, and the Federal Safe Drinking Water Act. Product is compliant to California Health and Safety Code 116875 (AB 1953-2006), and NSF/ANSI/CAN 61: Q ≤ 1.

OPTIONS

Bottle Filler Attachment: Model 3377BFG, bottle filler attachment for the Haws 3377G pedestal fountain utilizes a satin finish stainless steel bracket, 100% lead-free waterways, laminar flow, and a galvanized steel pedestal extension with no exterior treatment or processing for a rough, natural steel finish. Appearance of exterior may vary.

Faucet Valve: Model 6250LF, self-closing, plain end, lead-free, brass bib faucet with polished chrome-plated finish. (When used with Haws concrete products, also order part 0004499489; for 3511, use 0004521763)

Sand Trap: Model 6611, sand trap for installing adjacent to pedestal drinking fountains to help prevent debris and contaminants from clogging waste line.



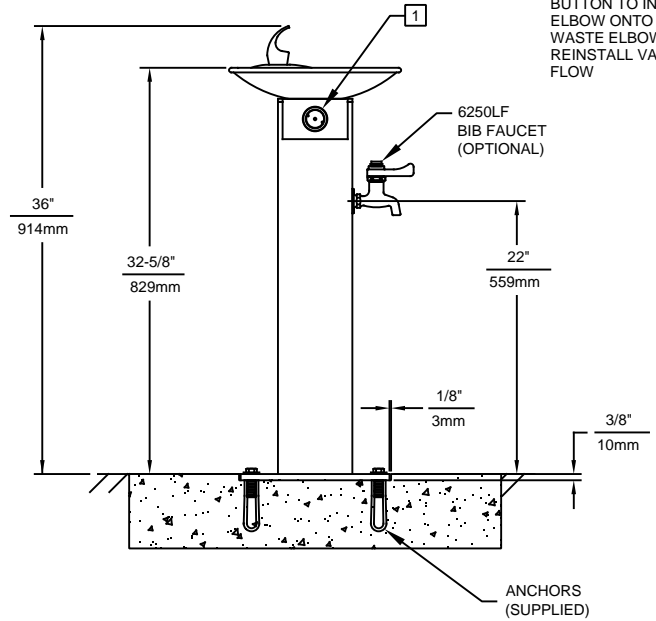
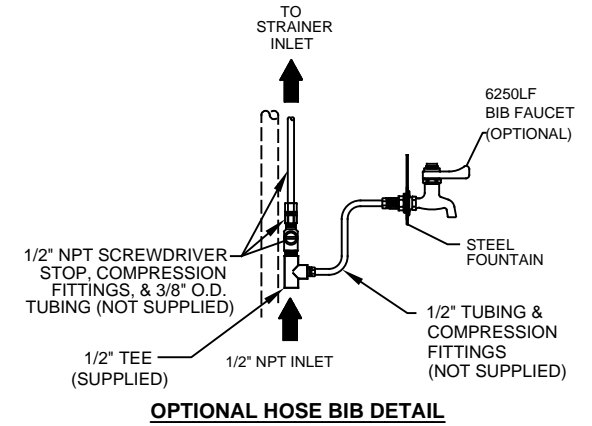
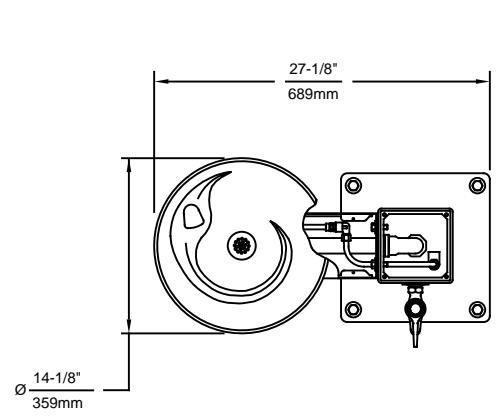
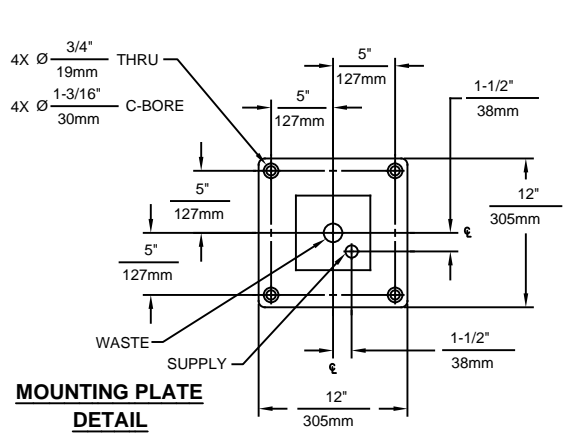

REMOVE VALVE FROM PUSH BUTTON TO INSTALL WASTE ELBOW ONTO BOWL. AFTER WASTE ELBOW IS INSTALLED, REINSTALL VALVE & ADJUST FLOW

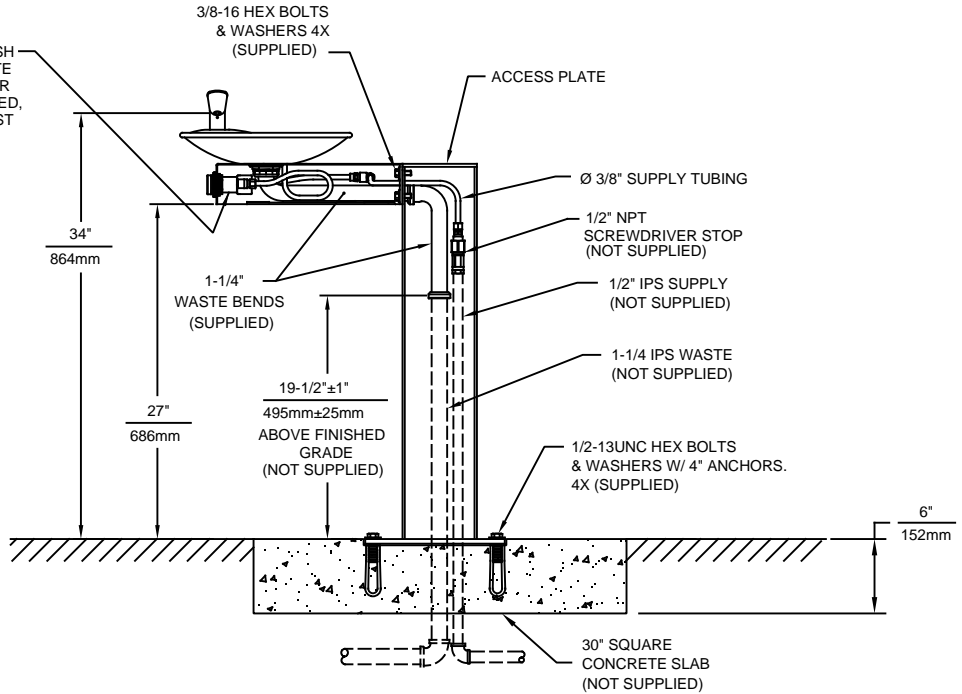

NOTES:
 1 REFER TO 5874 SERIES OPERATION AND MAINTENANCE MANUAL FOR PUSH BUTTON AND VALVE INSTALLATION/MAINTENANCE INSTRUCTIONS.

1455 KLEPPE LANE
 SPARKS, NEVADA 89431
 (775) 359-4712 FAX (775) 359-7424
 E-MAIL: HAWS@HAWS.CO.COM
 WEBSITE: WWW.HAWS.CO.COM

ECN NO. REVISED PER BY:		MODEL(S)		PART NUMBER	
DRAWN: RTM		DATE: 05/97		3377/3377G	
APPROVED: IR		DATE: 12/09/19		0002077364.D	
SCALE: 1:15		DRAWING TYPE: INSTALLATION		REVISION	
				15	
				SHEET 1 OF 1	