

## FEATURES & BENEFITS

### FOUNTAIN VALVE

The push-button activated valve offers the only all stainless steel valve body that is machined out of solid bar stock, is fully serviceable through the front of the push button assembly offering access to the water control cartridge and integral water supply strainer, and with front access to the water stream height adjustment for easy maintenance without having to remove the valve. Operating pressure range of 30 to 90 psi (2.1 to 6.2 bar).

### BOTTLE FILLER

With its patented stainless steel, push-button activated valve assembly which allows for front access stream adjustment as well as cartridge and strainer access, this bottle filler offers laminar flow and 100% lead free waterways. The valve works at an operating pressure range of 30 to 90 psi (2.1 to 6.2 bar).

### CONSTRUCTION

Heavy-duty 3/16" (.47 cm) galvanized steel pedestal attachment is supplied with a top down access plate and finished with green powder-coat paint.

### VANDAL RESISTANT

The push button and bottom plate are locked in place, discouraging unwanted vandal tampering.

### INSTALLATION

Bottle filler attachment can be ordered with a 3377 pedestal drinking fountain, or added to an existing installation.



## SPECIFICATIONS

Model 3377BF bottle filler attachment for the 3377 pedestal drinking fountain shall include a 14 gauge Type 304 Stainless Steel bottle filler bracket, and a 3/16" galvanized steel top-access pedestal extension with green powder-coated finish. It shall also include 100% lead-free waterways, 1 gpm (3.8 L) laminar flow, push-button operated stainless steel valve with front-accessible cartridge and flow adjustment, and a vandal-resistant bottom plate. May be an accessory to a new 3377 pedestal drinking fountain or retrofit to an existing 3377.

## OPTIONS

For more information, visit [www.hawsc.com](http://www.hawsc.com) or call (888) 640-4297.

## APPLICATIONS

Perfect for either public or private outdoor settings, the 3377BF is a great fit in areas where aesthetics are important to the overall appeal of the architecture. Suitable in areas where weather conditions exist, this series stands strong as a nice addition to any community. This type of pedestal bottle filler may also be placed in a variety of settings such as parks, schools, and other outdoor environments where the temperature remains above freezing. Haws manufactures drinking fountains, faucets and electric water coolers to be lead-free by all known definitions including NSF/ANSI/CAN 61-Section 9, NSF/ANSI/CAN 372, California Proposition 65, and the Federal Safe Drinking Water Act. Product is compliant to California Health and Safety Code 116875 (AB 1953-2006), and 116876 (AB 100) "NSF/ANSI/CAN 61: Q ≤ 1".



**INSTALLATION INSTRUCTIONS:**

- 1) VERIFY THAT THE WATER SUPPLY IS SHUT OFF TO THE FOUNTAIN.
- 2) REMOVE THE ACCESS PLATE FROM THE EXISTING 3377 PEDESETAL. CUT THE EXISTING 3/8" PLASTIC WATER SUPPLY LINE AND INSTALL THE 3/8" TEE WITH THE 24" TUBE EXTENSION COMING OUT THE TOP.
- 3) FEED THE WATER SUPPLY TUBE THROUGH HOLE IN THE BOTTOM PLATE OF THE PEDESTAL EXTENSION. BOLT THE PEDESTAL EXTENSION ONTO THE 3377 FOUNTAIN USING THE (4) 1/4-20 FLATHEAD BOLTS PROVIDED. A BALL-END HEX WRENCH IS RECOMMENDED FOR BOLT INSTALLATION.
- 4) INSTALL THE BOTTLE FILLER BRACKET ONTO THE PEDESTAL USING THE (4) 3/8-16 HEX BOLTS PROVIDED. CONNECT THE SUPPLY LINE TUBE TO THE PUSH BUTTON VALVE.
- 5) RE-INSTALL THE ACCESS PLATE ON TOP THE PEDESTAL EXTENSION.

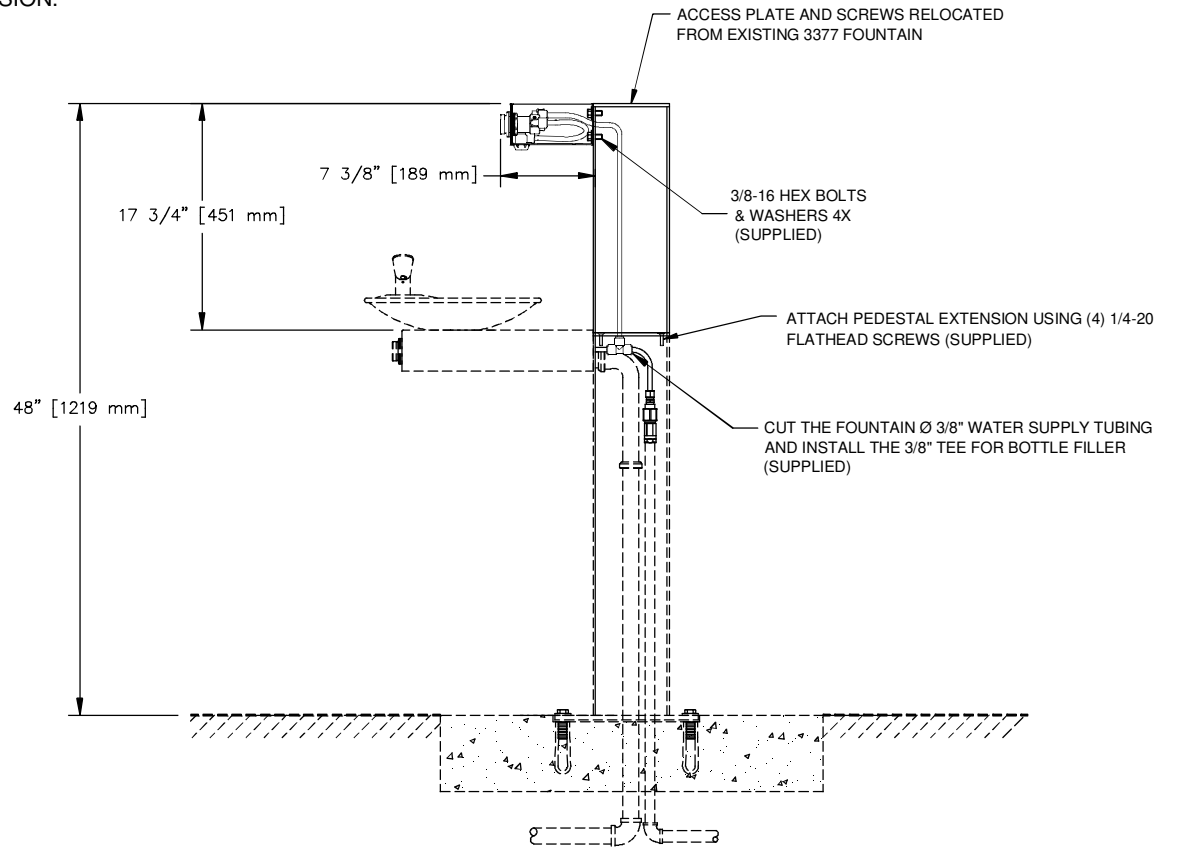
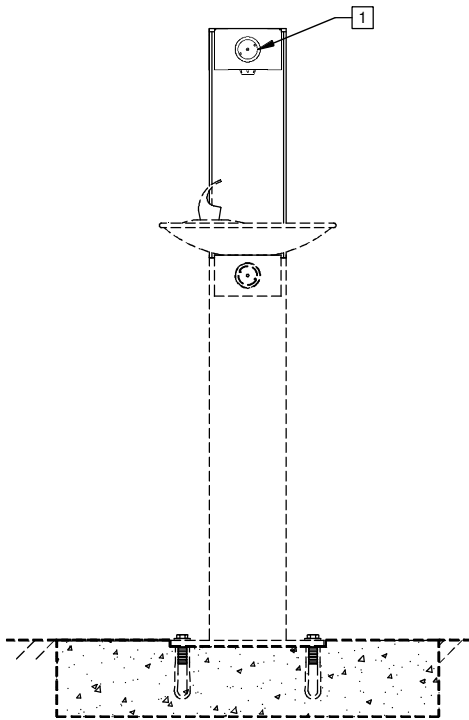
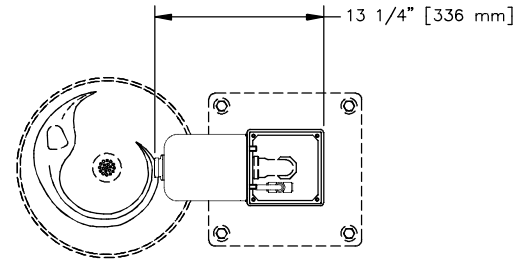

**NOTES:**

- 1 REFER TO 5874HF OPERATION AND MAINTENANCE MANUAL FOR PUSH BUTTON AND VALVE INSTALLATION/MAINTENANCE INSTRUCTIONS.

		<b>Haws</b> <sup>®</sup>		1455 KLEPPE LANE SPARKS, NEVADA 89431 (775) 359-4712 FAX (755) 359-7424 E-MAIL: HAWS@HAWS.CO.COM WEBSITE: WWW.HAWS.CO.COM	
				ECON NO: 5081 DRAWN: MJ APPROVED: JL	REVISED PER BY: ECN:5081 RVH DATE: 06/08/16 DATE: 06/22/16
SCALE: 1:15		DRAWING TYPE: INSTALLATION		SIZE: A SHEET 1 OF 1	