



model 1930

Replacement Bottle Filler Attachment

FEATURES & BENEFITS

OPTIONS

For more information, visit www.hawesco.com or call (888) 640-4297.



SPECIFICATIONS

Model 1930 replacement bottle filling portion of the Haws 1211 and 1212 series water coolers. Completely assembled and tested attachment is ready for easy replacement.

APPLICATIONS

Specifically, this is used as a replacement when vandalism occurs, or for the rare occasion the sensor might quit working.

REPLACEMENT INSTRUCTIONS:

1. **REQUIRED TOOLS:** PHILLIPS SCREWDRIVER (OR 5/16 NUT DRIVER), 1/4" BIT DRIVER, T25 TORX BIT (SUPPLIED),
2. DISCONNECT ELECTRICAL POWER TO UNIT.
3. REMOVE THE COOLER SKIRT(S).
4. IF A HI-LO UNIT IS INSTALLED, THE HIGH UNIT MAY NEED TO BE REMOVED IN ORDER TO ACCESS THE MOUNTING SCREW ON THE LEFT SIDE OF THE RIGHT UNIT. REFERENCE COOLER OPERATION AND MAINTENANCE MANUAL.
5. REMOVE BOTH MOUNTING SCREWS.
6. DISCONNECT BOTTLE FILLER INLET TUBING FROM ELBOW CONNECTOR. REMOVE LOWER PIECE OF TUBING INSULATION.
7. SLIDE BOTTLE FILLER UP AND AWAY FROM UPPER MOUNTING BRACKET UNTIL WIRING HARNESS CONNECTOR IS ACCESSIBLE. DISCONNECT THE WIRING HARNESS.
8. ASSEMBLE THE NEW BOTTLE FILLER, FOLLOWING THE STEPS ABOVE BUT IN REVERSE.
9. RE-INSTALL THE HIGH UNIT IF IT WAS PREVIOUSLY REMOVED. REFERENCE COOLER OPERATION AND MAINTENANCE MANUAL.
10. RE-INSTALL THE COOLER SKIRTS.
11. RECONNECT ELECTRICAL POWER TO THE UNIT
12. RUN THE BOTTLE FILLER TO PURGE AIR FROM THE SYSTEM.

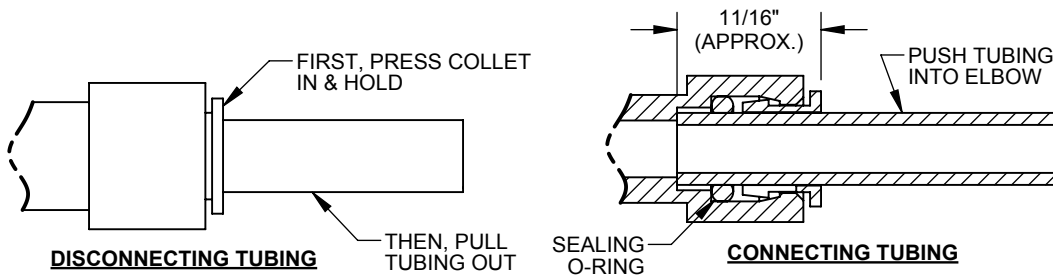

DISCONNECTING & RE-CONNECTING TUBING

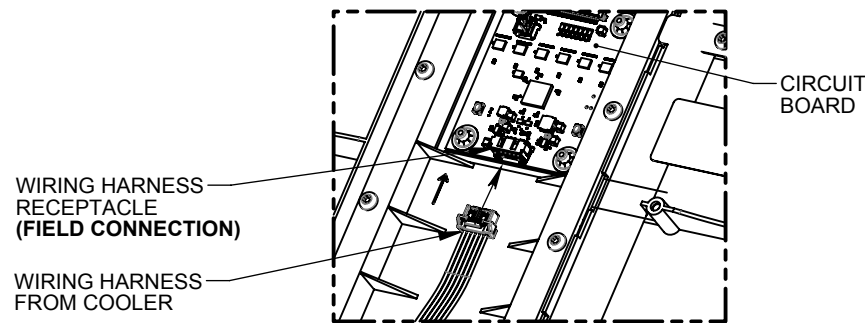

**WIRING HARNESS CONNECTION
(REAR OF BOTTLE FILLER)**

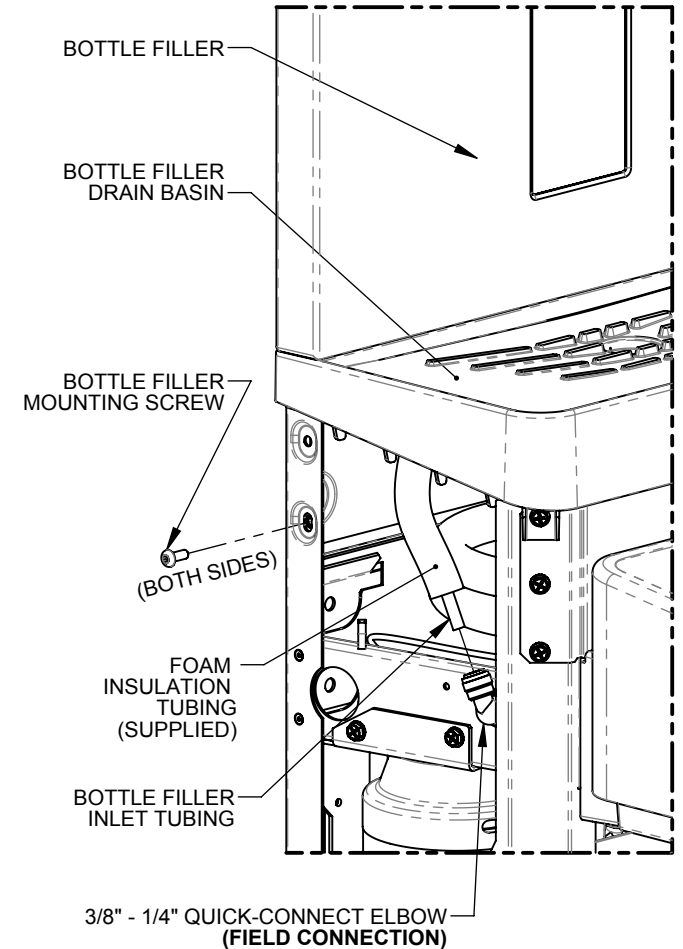

BOTTLE FILLER MOUNTING & TUBING CONNECTION



1455 KLEPPE LANE
SPARKS, NEVADA 89431
(775) 359-4712 FAX (775) 359-7424
E-MAIL: HAWS@HAWSO.COM
WEBSITE: WWW.HAWSO.COM

ECN: 5357	REV. ECN: 5357	BY: JL	MODEL(S) 1930 - REPLACEMENT 12XX BOTTLE FILLER	PART NUMBER 0510000959
DRAWN: JL	DATE: 07/25/19	CHKD: DHP		REVISION 1
APPROVED: BM	DATE: 06/27/19	SCALE: 1:2	DRAWING TYPE: INSTALLATION	SIZE: A
				SHEET 1 OF 1