

## FEATURES & BENEFITS

### CONSTRUCTION

Medium Grey ABS plastic construction aesthetically blends in with stainless steel drinking fountain basins, and easily resists stains and fingerprints.

### UNIVERSAL MOUNTING

This unit is perfect as a stand-alone bottle filling station, or easily located over virtually any wall mounted drinking fountain or water cooler with its quick mount wall frame. The unit connects to the fountain's water line, and naturally drains into the waste so there is no need for new water or drain lines.

### VALVE

With its patented stainless steel, push-button activated valve assembly which allows for front access stream adjustment as well as cartridge and strainer access, this bottle filler offers 100% lead free waterways. The valve works at an operating pressure range of 30 to 90 psi (2.1 to 6.2 bar).

### USEABLE FOOTPRINT

With its narrow width dimensions of only 8-1/4" (21 cm), this bottle filler can be mounted above almost any drinking fountain with ease. This compact size does not take away from its large bottle filling area accommodating bottle sizes up to 10" (25.4 cm) high.

### REVERSIBLE DRAIN TRAY

Flexible drain design allows for outward drain tray to be reversed inward allowing drain water to be connected to waste inside of wall.

## OPTIONS

- Remote Drinking Fountain Water chiller: Model HCR8, 8 gph (30.3 L) remote water chiller provides instantaneous cooling to meet a continuous demand for chilled water.

For more information, visit [www.hawsc.com](http://www.hawsc.com) or call (888) 640-4297.



## SPECIFICATIONS

Model 1900 wall mounted bottle filler shall include 100% lead-free waterways, push-button operated stainless steel valve with front-accessible cartridge and flow adjustment, reversible waste attachment for over-fountain or in-wall waste drain, medium grey ABS plastic construction, and easy to use mounting frame with easy to follow mounting instructions.

## APPLICATIONS

This type of wall mounted bottle filler may be placed in settings such as: schools and other locations in and around office buildings with existing fountain installations where the temperature remains above freezing. Model meets all current Federal Regulations for the disabled including those in the Americans with Disabilities Act. Haws manufactures drinking fountains, faucets and electric water coolers to be lead-free by all known definitions including NSF/ANSI/CSA 61-Section 9, NSF/ANSI/CSA 372, California Proposition 65, and the Federal Safe Drinking Water Act. Product is compliant to California Health and Safety Code 116875 (AB 1953-2006), and 116876 (AB 100) "NSF/ANSI/CAN 61: Q ≤ 1".



**NOTES:**

1. HOLD ROUGH-IN DIMENSIONS  $\pm 1/4"$  (6.4mm).
2. WHEN INSTALLING THIS UNIT, LOCAL, STATE, OR FEDERAL CODES SHOULD BE ADHERED TO. FOR INSTALLATION HEIGHTS OTHER THAN SHOWN, DIMENSIONS MARKED (\*) MUST BE ADJUSTED ACCORDINGLY. INSTALL A TRAP IN THE WASTE LINE AND A SCREWDRIVER STOP IN THE SUPPLY LINE IF REQUIRED.
- 3 REFER TO 5874 SERIES OPERATION & MAINTENANCE MANUAL FOR PUSH BUTTON AND VALVE INSTALLATION & MAINTENANCE INSTRUCTIONS.
- 4 BOTTLE FILLER IS SHOWN INSTALLED AT ADA MAXIMUM OBSTRUCTED FORWARD REACH HEIGHT. FOR ADA OBSTRUCTED SIDE REACH COMPLIANCE, BOTTLE FILLER MUST BE LOWERED 2". ADA COMPLIANCE DEPENDS ON OVERALL SIZE OF WATER COOLER OR DRINKING FOUNTAIN (SEE SHEETS 3 & 4).

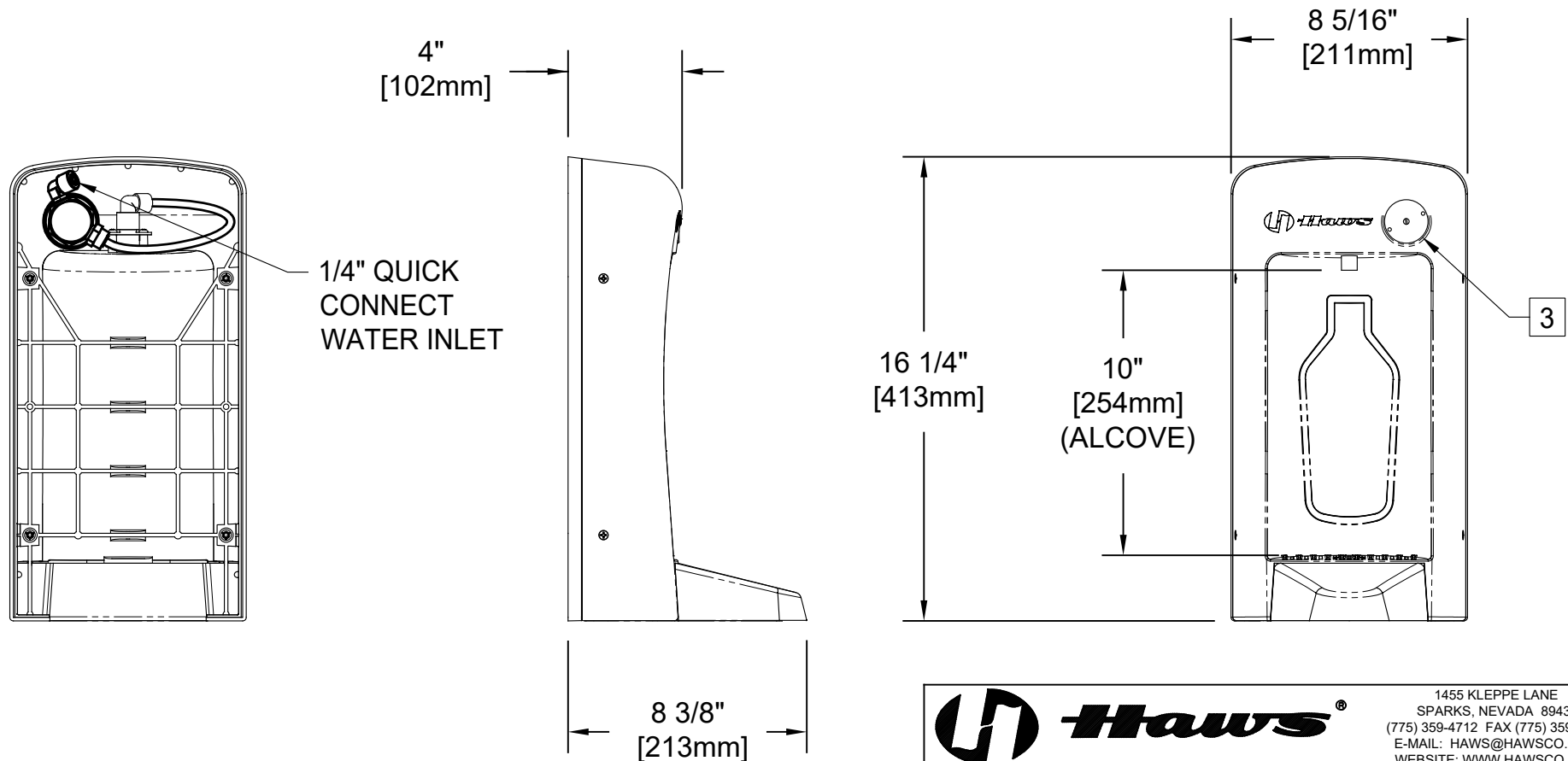

|   |  |                            |  |   |   |
|---|--|----------------------------|--|---|---|
|  |  | <b>Haws</b> <sup>®</sup>   |  | 1455 KLEPPE LANE<br>SPARKS, NEVADA 89431<br>(775) 359-4712 FAX (775) 359-7424<br>E-MAIL: HAWS@HAWSO.COM<br>WEBSITE: WWW.HAWSO.COM |   |
|   |  |                            |  | ECN NO. 4855<br>DRAWN: JL<br>APPROVED: FV   | REVISED PER: ECN: 5766<br>DATE: 2/10/14<br>DATE: 02/03/22 |
| SCALE: 1:1  |  | DRAWING TYPE: INSTALLATION |  | SIZE: A SHEET 1 OF 4  |   |