

## FEATURES & BENEFITS

### CONSTRUCTION

Heavy-duty cast iron bowl with a glossy white enamel finish is designed for the toughest of applications, and at the same time is gentle to all users with its soft rounded corners. Unit also ships with vandal-resistant bottom plates to provide added peace of mind.

### INTEGRATED TRAP

All cast brass 1-1/4" NPT adjustable traps completely concealed inside bottom plates for easy installation and lack of unwanted access.

### BARRIER-FREE

ADA capabilities combined with its ease of use allow for a number of installation location possibilities.

### MOUNTING

3/16" (.47 cm) thick steel mounting plate is larger, thicker and stronger than any other plate in the industry, and shall include the all-thread studs, nuts, and washers which allows for easy installation to a framed wall.

### BUBBLER HEADS

Polished chrome-plated brass bubbler heads with integral 11/16" dia. basin shank and stainless anti-rotation roll pin for vandal resistance strength. Shielded, angled stream opening provides a steady, sanitary source of drinking water at .45 gpm.

### DRINKING FOUNTAIN VALVES

The push-button activated valves offer the only all stainless steel valve body that is machined out of solid bar stock, is fully serviceable through the front of the push button assembly offering access to the water control cartridge and integral water supply strainer, and with front access to the water stream height adjustment for easy maintenance without having to remove the valve. Operating pressure range of 30 to 90 psi (2.1 to 6.2 bar).

### VANDAL-RESISTANT

The bubbler heads, push buttons, drain strainers and bottom plates are locked in place, discouraging unwanted vandal tampering.

## OPTIONS

- Bottle Filler: Model 1920W bottle filler can be a standalone station, or mounted above Haws 1311 and 1501 series drinking fountain models.
- Bottle Filler Stand: Model BTL1311, add-on stainless steel stand to place bottle on when 1920 bottle filler is used.
- Support Frame: Model 6800 In-wall floor mounted fixture support legs, welded steel 4-bolt floor flanges, and supplied with 'U' bolts and hardware.
- Cane Detection, Floor Mounted: Model SK6, floor mounted cane detection for the Haws Hi-Lo drinking fountains.

For more information, visit [www.hawsco.com](http://www.hawsco.com) or call (888) 640-4297.



## SPECIFICATIONS

Model 1501 wall-mounted barrier-free vandal-resistant drinking fountain shall include dual white enameled-iron basins, vandal-resistant push-button operated stainless steel valves with front-accessible cartridge and flow adjustment, 100% lead-free waterways, polished chrome-plated brass vandal-resistant bubbler heads, polished chrome-plated brass vandal-resistant waste strainers, vandal-resistant bottom plates, white powder-coated stainless steel back panel and 1-1/4" NPT traps.

## APPLICATIONS

Perfect for either public or private settings, our gleaming white enameled iron series is one of the sturdiest wall mounted fountains Haws produces. This unit is the perfect fit for high traffic areas where there is a greater need for multiple drinking stations. Elegant gloss finish and color consistency throughout the enameled iron maintain the fountain's overall appeal so it always remains looking as new as it did when it was installed. Specifically, this type of wall mounted drinking fountain may be placed in settings such as: parks, schools, and other indoor/outdoor environments where the temperature remains above freezing. Model meets all current Federal Regulations for the disabled including those in the Americans with Disabilities Act. Haws manufactures drinking fountains, faucets and electric water coolers to be lead-free by all known definitions including NSF/ANSI/CAN 61- Section 9, NSF/ANSI/CAN 372, California Proposition 65, and the Federal Safe Drinking Water Act. Product is compliant to California Health and Safety Code 116875 (AB 1953-2006), and NSF/ANSI/CAN 61: Q ≤ 1.



**NOTES:**

- 1 1 1/4" DIM TO SLOTTED OPENING ON THE MOUNTING PLATE MUST BE ON THE TOP LEFT HAND SIDE WHEN INSTALLED.
- 2 1 1/2" DIM TO SLOTTED OPENING ON THE BACKPANEL MUST BE ON TOP LEFT HAND SIDE WHEN INSTALLED.
3. HOLD ROUGH-IN DIMENSIONS ± 1/4" (6.4MM).
4. WHEN INSTALLING THIS UNIT, LOCAL, STATE, OR FEDERAL CODES SHOULD BE ADHERED TO. FOR INSTALLATION HEIGHTS OTHER THAN SHOWN, DIMENSIONS MARKED (\*) MUST BE ADJUSTED ACCORDINGLY.
- 5 REFER TO 5874 SERIES OPERATION AND MAINTENANCE MANUAL FOR PUSH BUTTON AND VALVE INSTALLATION/MAINTENANCE INSTRUCTIONS.

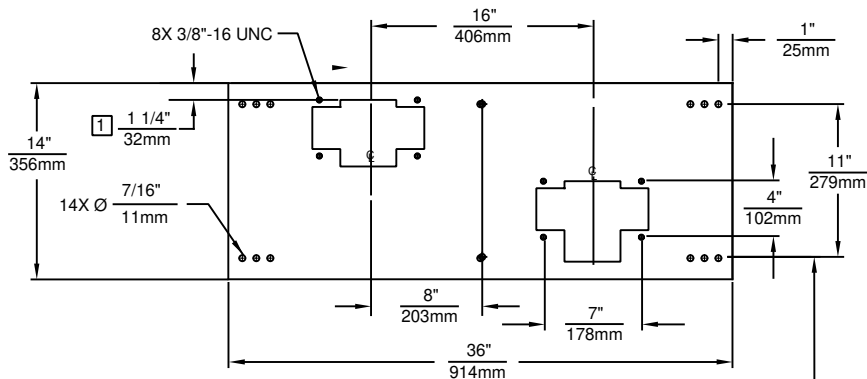

**6715 MOUNTING PLATE**  
MUST BE INSTALLED BEFORE FINISH WORK.  
THIS PLATE IS REQUIRED - SOLD SEPARATELY.

FLOOR LINE

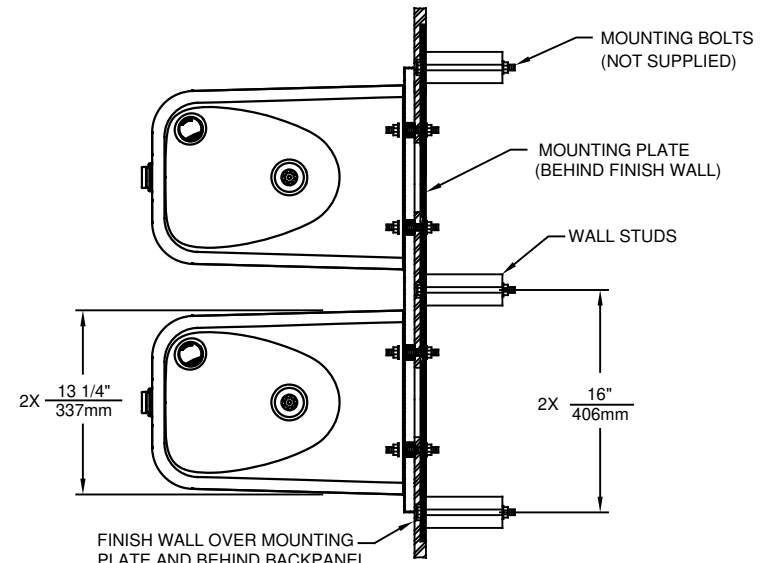
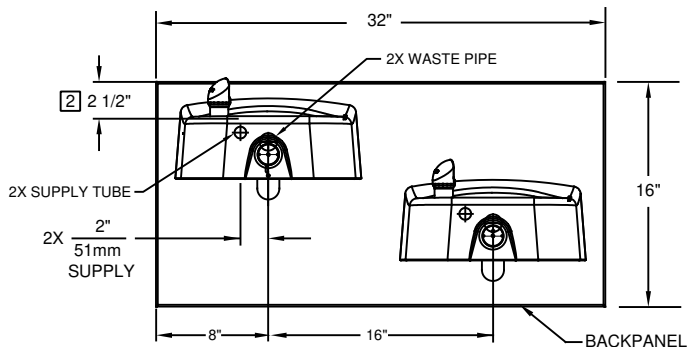

FINISH WALL OVER MOUNTING PLATE AND BEHIND BACKPANEL. BE CAREFUL THAT FINISHED WALL EXTENDS WITHIN THE HAWS BACKPANEL.

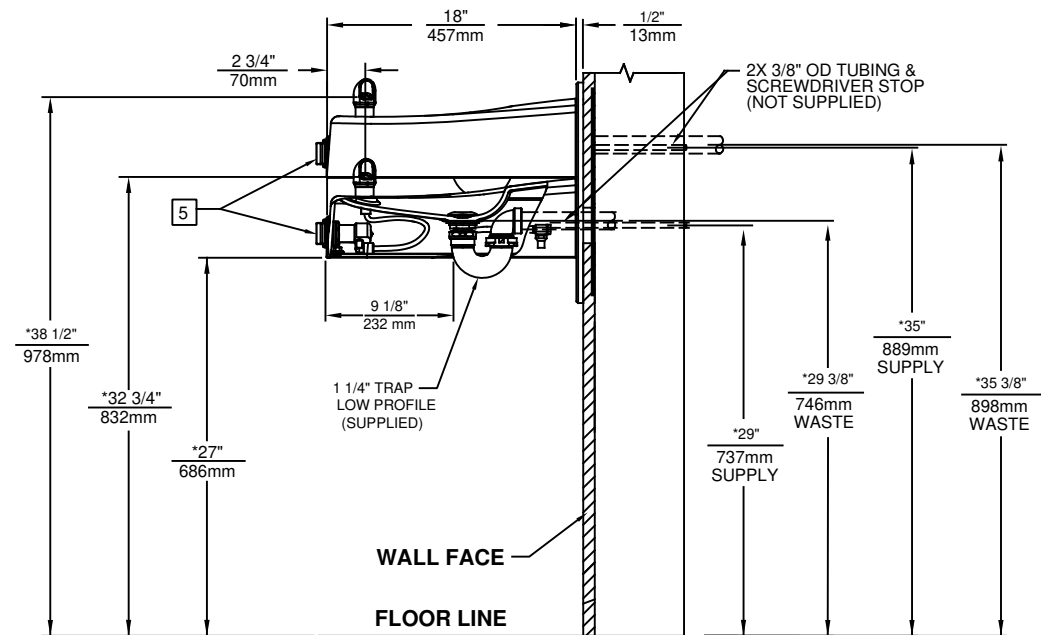

1455 KLEPPE LANE  
SPARKS, NEVADA 89431  
(775) 359-4712 FAX (775) 359-7424  
E-MAIL: HAWS@HAWS.CO.COM  
WEBSITE: WWW.HAWS.CO.COM

ECN NO. 5010	REVISED PER ECN: 5527	BY: FV	MODEL(S)	1501	PART NUMBER
DRAWN: HM	DATE: 08/25/15	CHK'D: DP			0510000047.D
APPROVED: FV	DATE: 04/02/20		SCALE: 1:1	DRAWING TYPE: INSTALLATION	REVISION
					5
				SIZE: A	SHEET 1 OF 1