

FEATURES & BENEFITS

CONSTRUCTION

Rugged ADA accessible 18 gauge Type 304 Stainless Steel swirl design bowls, 14 gauge Type 304 Stainless Steel brackets, and a vandal-resistant bottom plate provides a long lasting unit with added peace of mind.

MOUNTING

Galvanized frame and 10 gauge surface plate provide the maximum mounting strength for the 'Hi-Lo' MS style Haws drinking fountains.

BUBBLER HEADS

Polished chrome-plated brass bubbler heads with integral laminar flow prevents splashing while providing a superior flow pattern. The integral 11/16" dia. basin shank and stainless anti-rotation roll pin for vandal resistance strength. Shielded, angled stream opening provides a steady source of drinking water at .45 gpm.

DRINKING FOUNTAIN VALVES

The push-button activated valve offers the only all stainless steel valve body that is machined out of solid bar stock, is fully serviceable through the front of the push button assembly offering access to the water control cartridge and integral water supply strainer, and with front access to the water stream height adjustment for easy maintenance without having to remove the valve. Operating pressure range of 30 to 90 psi (2.1 to 6.2 bar).

VANDAL-RESISTANT

The bubbler heads, push buttons, round bowls, drain strainers and bottom plates are locked in place, discouraging unwanted vandal tampering.

CUSTOM LOGO PANEL

Personalize your new or existing fountain or bottle filler where space permits with an optional customizable 10" high by 4.25" wide stainless steel panel. Virtually any company logo, event logo or graphic can be placed on this panel. Mounted with strong, moisture-resistant adhesive backing.

OPTIONS

- Bottle Filler: Model 1920, stainless steel bottle filler can be a stand-alone station, or mounted above Haws 1001 and 1011 series drinking fountain models.
- Bottle Filler Stand: Model BTL1001, add-on stainless steel stand to place bottle on when 1920 bottle filler is used.
- Remote Drinking Fountain Water chiller: Model HCR8, 8 gph (30.3 L) remote water chiller provides instantaneous cooling to meet a continuous demand for chilled water.
- Custom Logo Panel: Model 6475, Hydration By Haws[®] logo panel with customization options.

For more information, visit www.hawscow.com or call (888) 640-4297.



SPECIFICATIONS

Model 1011MS vandal-resistant wall mounted barrier-free drinking fountain shall include dual 18 gauge Type 304 stainless steel satin finish basins with integral swirl design, 14 gauge Type 304 satin finish stainless steel wall brackets, 100% lead-free waterways, vandal-resistant push-button operated stainless steel valves with front-accessible cartridge and flow adjustment, polished chrome-plated brass vandal-resistant bubbler heads with integral laminar anti-squirt flow, chrome-plated brass vandal-resistant waste strainers, vandal-resistant bottom plates, stainless steel finish back and access panels allowing for front access of P-trap and stop, in-wall mounting frame, high and low fountain mounting levels, and 1-1/4" O.D. (3.2 cm) waste.

REQUIRES MODEL MTGFR.DF2 PRICED SEPARATELY.

APPLICATIONS

Perfect for either public or private indoor/outdoor settings, Model 1011MS is a great fit in areas where aesthetics are important to the overall appeal of the architecture. This series is precisely mounted, making it a nice addition to any surrounding. Beautiful high-polished finish helps to maintain the fountains overall appeal so it always remains looking as new as it did when it was installed. Specifically, this type of wall mounted drinking fountain may be placed in settings such as: schools and other locations in and around office buildings where the temperature remains above freezing. Model meets all current Federal Regulations for the disabled including those in the Americans with Disabilities Act. Haws manufactures drinking fountains, faucets and electric water coolers to be lead-free by all known definitions including NSF/ANSI/CAN 61-Section 9, NSF/ANSI/CAN 372, California Proposition 65, and the Federal Safe Drinking Water Act. Product is compliant to California Health and Safety Code 116875 (AB 1953-2006), and NSF/ANSI/CAN 61: Q ≤ 1.



NOTES:

- 1 HOLD ROUGH-IN DIMENSIONS $\pm 1/8"$ (3.2mm).
- 2 WHEN INSTALLING THIS UNIT, LOCAL, STATE, OR FEDERAL CODES SHOULD BE ADHERED TO FOR DIMENSIONS (LOCATIONS), WASTE AND SUPPLY REQUIREMENTS OTHER THAN SHOWN.
- 3 INSTALLER MUST PROVIDE TRAP FOR PROPER INSTALLATION.
- 4 HOLE COMBINATION SHOWN BELOW IS FOR USE WITH LOW FOUNTAIN ON THE RIGHT AND HIGH FOUNTAIN ON THE LEFT. USE OPPOSITE HOLES FOR HIGH ON RIGHT AND LOW ON LEFT.
- 5 TO CHANGE FOUNTAIN MTG. SCREW LOCATIONS: FIRST REMOVE SCREWS AND THEN SQUEEZE CLIPS ON NUT RETAINER TO POP OUT. SNAP INTO NEW POSITIONS FROM BACKSIDE AND RE-ASSEMBLE SCREWS.
- 6 IMPORTANT: A L.H. LOW (OPTIONAL) CONFIGURATION WILL REQUIRE A DIFFERENT BACK PANEL AND THE WASTE AND SUPPLY DIMENSIONS SHOWN (*) MUST BE REVERSED.
- 7 REFER TO 5874 SERIES OPERATION AND MAINTENANCE MANUAL FOR PUSH BUTTON AND VALVE INSTALLATION/MAINTENANCE INSTRUCTIONS.

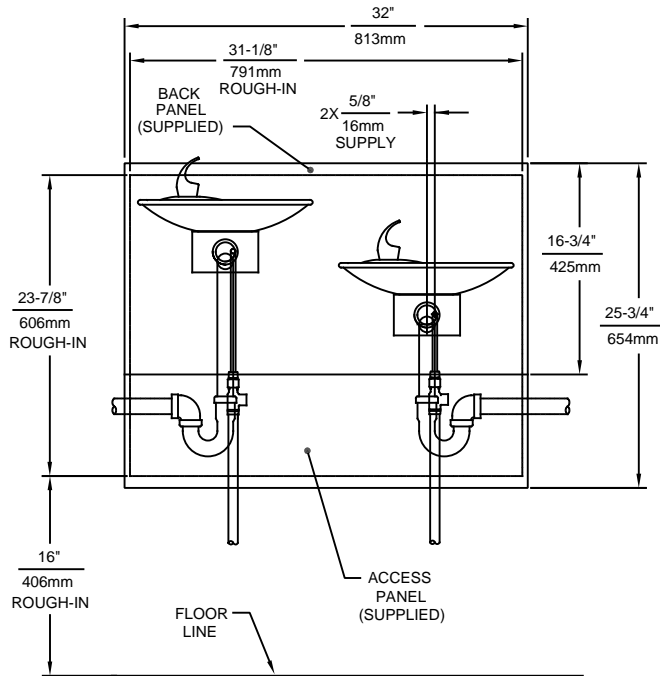
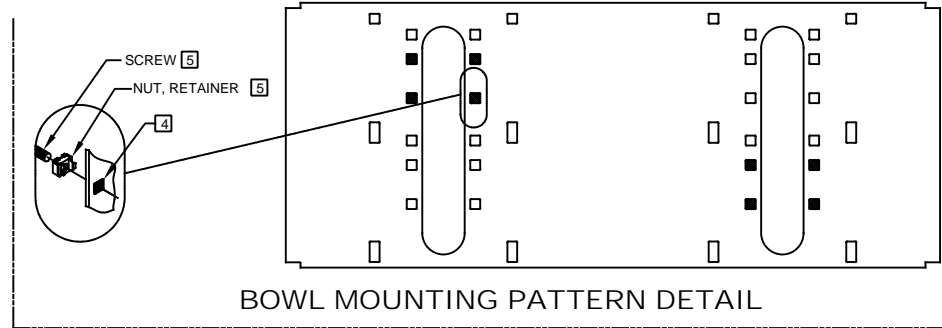
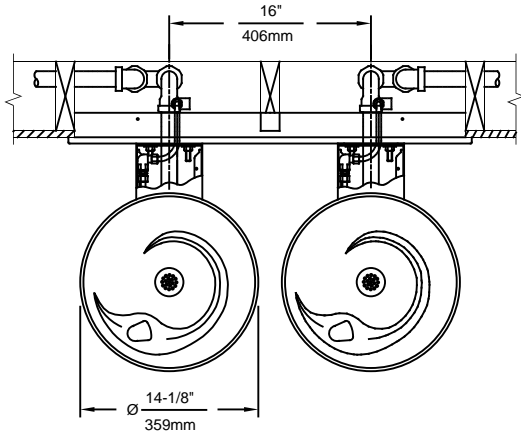

REMOVE VALVE FROM PUSH BUTTON TO INSTALL WASTE ELBOW ONTO BOWL. AFTER WASTE ELBOW IS INSTALLED, REINSTALL VALVE & ADJUST FLOW

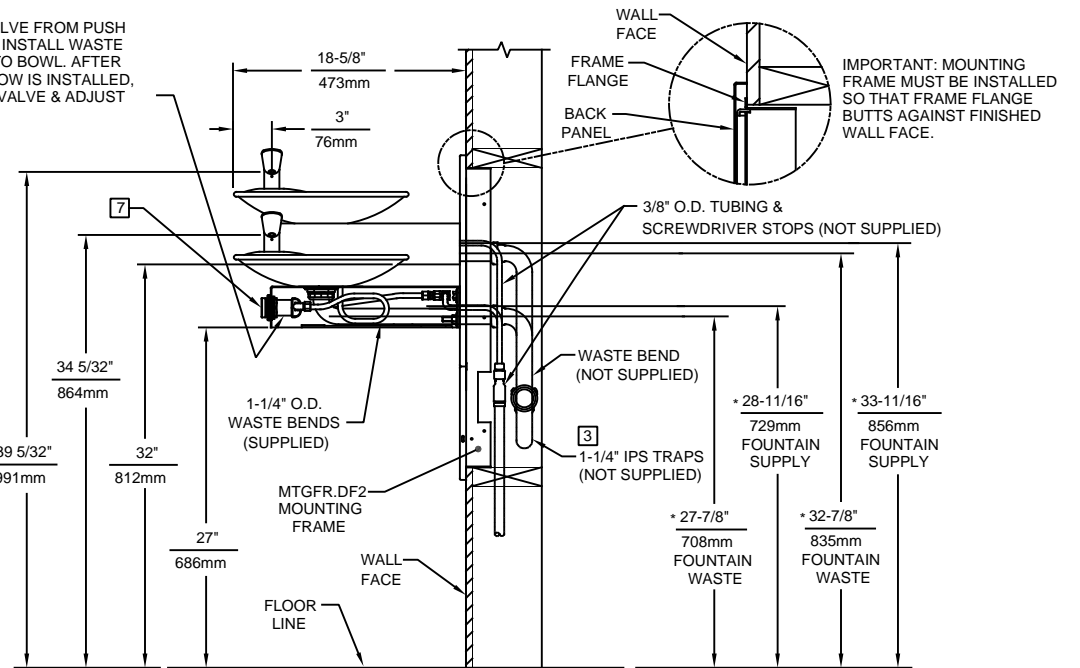

Haws

1455 KLEPPE LANE
SPARKS, NEVADA 89431
(775) 359-4712 FAX (775) 359-7424
E-MAIL: HAWS@HAWSCO.COM
WEBSITE: WWW.HAWSCO.COM

ECN NO.	REVISED PER	BY:	MODEL(S)	PART NUMBER
	ECN: 5124	VWC		0002076519.D
DRAWN: PM	DATE: 08/02/99	CHKD: VWC	1011HPSMS/1011MS DRINKING FOUNTAIN	REVISION
APPROVED: FV	DATE: 07/06/17			11
			SCALE: 1:16	DRAWING TYPE: INSTALLATION
			SIZE: A	SHEET 1 OF 1