



INSTALLATION, OPERATION & MAINTENANCE INSTRUCTIONS

1455 Kleppe Lane ♦ Sparks, NV 89431-6467 ♦ (775) 359-4712 ♦ Fax (775) 359-7424
E-mail: haws@hawsco.com ♦ website: www.hawsco.com

No. 0002080262 (22)

Model H1119.8 Water Cooler

NOTE TO INSTALLER: Please leave this information with the Maintenance Department.

Haws electric water cooler's are not designed or recommended for outdoor or corrosive environments such as enclosed chlorinated pool areas.

Consideration must be made at the time of installation to adhere to state and/or local codes and environmental/atmospheric conditions such as, but not limited to, dust, corrosion, freezing etc. These conditions will void the warranty.

CAUTION! Prior to making any electrical connections, verify with a voltmeter that power from the service panel is **off**.

LIMITED WARRANTY

HAWS warrants that this specific product is guaranteed against defective material or poor workmanship for a period of **one year from date of shipment**. HAWS liability under this warranty shall be discharged by furnishing without charge F.O.B. HAWS Factory any goods, or part thereof, which shall appear to the Company upon inspection to be of defective material or not of first class workmanship, provided that claim is made in writing to Haws within a reasonable period after receipt of the product. Where claims for defects are made, the defective part or parts shall be delivered to the Company, prepaid, for inspection. HAWS will not be liable for the cost of repairs, alterations or replacements, or for any expense connected therewith made by the owner or his agents, except upon written authority from HAWS, Sparks, Nevada. HAWS will not be liable for any damages caused by defective materials or poor workmanship, except for replacements, as provided above. Buyer agrees that HAWS shall not be liable for general, special, or consequential damages claimed to arise under the contract of sale. The drinking fountain manufactured by HAWS is warranted to function if installation and maintenance instructions provided are adhered to. The units also must be used for the purpose for which they were intended.

NO OTHER WARRANTIES EXPRESSED OR IMPLIED ARE AUTHORIZED, PROVIDED OR GIVEN BY HAWS.

SHOULD YOU EXPERIENCE DIFFICULTY WITH THE INSTALLATION OF THIS MODEL PLEASE CALL:

TECHNICAL SUPPORT: 1-800-766-5612

FOR CUSTOMER SERVICE: 1-888-640-4297

RECOMMENDED TOOLS: Hack saw, pipe joint sealant, screwdriver, level, 12" adjustable wrench, 10" pipe wrench, 5/64" hex key wrench, 9/16", 1/2", 7/16" socket wrench or open end wrench.

LOCATION OF UNIT: The Model H1119.8 Cooler is a wheelchair accessible drinking facility. The height dimensions shown, meet current ADA requirements. When installing this unit, local, state or federal codes should be adhered to. If height other than shown is required, then dimensions must be adjusted accordingly.

SUPPLY LINE: The minimum recommended line size is 1/2"IPS with 30-90 psi (2-6 ATM) flowing pressure. Where sediment or mineral content is a problem, an inlet filter is recommended.

PLUMBING CONNECTIONS: Inlet is 3/8" O.D. push-in type fitting. Waste trap outlet is female 1-1/4" IPS.

ELECTRICAL CONNECTIONS: 115VAC, 60HZ, 4.7 AMPS. Chiller wired direct to incoming line, by others.

PARTS LIST

MODEL PACKAGE	QUANTITY	ITEMS INCLUDED
MTGFR.LG	1	Mounting Frame (Required – Sold Separately)
	3	#10 Sheet Metal Screws
HCR8	1	Chiller
H1119.8	1	Bowl Assembly
	1	Package supply tubing and fittings
	1	Grille
	2	Trap 1-1/4" IPS
	1	Package of two each grille attachment clips, clip nuts, #10 sheet metal screws and 6-32 screws
	8	5/16 -18 retainer nuts
	8	5/16 – 18 x 1 hex head screws

INSTALLATION PROCEDURE

GENERAL NOTES:

The Model H1119.8 Water Cooler assembly requires installation of the mounting frame as described in Steps 1 - 2, then mounting the fountain bowl assembly as described in Steps 3 - 6, and finally completing chiller water and electrical connections and starting chiller per Steps 7 - 11. First check that all required parts are received.

Grounding may cause electrical feedback into the electric drinking fountain causing an electrolysis, which creates a metallic taste or an increase in the metal content of the water. This condition can be avoided by using dielectric couplings in the assembly. The waste line, which is supplied by the installer, should also have a dielectric (plastic) coupling to completely isolate the assembly from the building plumbing system.

NOTES:

1. For all plastic push-in type fitting connections, only connect NSF-61 copper or plastic tubing. Stainless steel or glass tubing is not recommended. The following assembly instructions must be followed to ensure a watertight connection:
 - a. Cut tubing square and clean.
 - b. Mark from end of tube the length of insertion (See table below).
 - c. Push tube into the fitting until it bottoms out.
 - d. To remove, depress collet and pull tubing out.

Tube Sizes	O.D. Tolerance	Insertion Depth
1/4"	±.005"	11/16"
3/8"	±.005"	3/4"
1/2"	±.005"	7/8"

- STEP 1:** Provide wall opening as detailed in Installation Drawing. Frame must be positioned such that frame flanges overlap and butt against finished wall surface. Mounting holes are provided for #6 sheet metal screws. After frame is positioned in wall, swing chiller support tray into position (See Installation Drawing), align tray holes with holes in frame and fasten with #10 sheet metal screws. Mounted frame must support 50-pound chiller in addition to fountain weight and user generated forces.
- STEP 2:** Install waste, supply and electrical lines in locations shown in Installation Drawing. Waste and supply lines may be installed for either rear or side entry. Verify proper waste, supply, electrical and frame locations. Use level to verify horizontal and vertical frame mounting to insure proper bowl drainage.
- STEP 3:** Installation Drawing shows fountain bowls, back panel and grille locations. Unpack bowls and remove bottom plates using 5/64" hex allen wrench. Install back panel on frame with narrower edge to bottom. Position nut retainers into mounting frame and use two 5/16-18x1 hex head screws partially started in outside holes to support panel. Install bowl/bracket assembly onto panel using eight 5/16-18x1 hex head screws hand tightened. See sheet 2 of Installation Drawing for appropriate bowl mounting pattern to use for this model.

INSTALLATION PROCEDURE...

- STEP 4:** Remove 1-1/4" IPS outlet elbow from traps as supplied. Install elbow inside frame onto waste stub-outs.
- STEP 5:** Assemble waste trap onto bowl strainer using seal washer provided and tighten nut hand tight.
- STEP 6:** See Figure 1 for detail section view of side screw grille attachment. Unpack grille and insert upper lip behind bottom of back panel, align sides and hold up flush to bottom of back panel. Hold grille against wall and mark centers of grille side slots on wall. Masking tape may be used to prevent finished wall damage from mark. Install the "s" clips in mounting frame using #10 sheet metal screws into pre-drilled holes on lower end of each side of frame. Tighten #10 screw while holding "s" clips centered on wall marks. Check grille fit by installing grille and partially tightening #6-23 socket head screws through side of grille. Insure proper panel and grille alignment, then tighten eight 5/16-18x1 hex head screws.
- STEP 7:** Unpack and remove chiller from carton. Remove front panel screws and panel. Do not remove insulating putty and foam from copper tubes or Styrofoam insulation from evaporator coil. Remove any inner packing, which may be around compressor. If applicable, remove junction box cover and electrical knock out on lower right side of housing. Install fittings (supplied) on chiller inlet and outlet tubes (see Installation Drawing).
- STEP 8:** Thoroughly flush supply line to remove all foreign matter. Connect 1/2" IPS supply screwdriver stop to stub-out in wall. Place chiller on chiller support tray against right hand side, fully to rear, with condenser (open panel) side facing to front. Install supply 3/8" O.D. tubing (not supplied) between screwdriver stop and chiller inlet. (Cut tubing to proper length, and follow general notes for proper connection procedures for push-in type fittings). Tubing insulation is not normally required on inlet side of chiller. Install insulated tube between fountain and solenoid valve outlet. Cut tubes as required and connect to chiller outlet compression tee assembly. Open screwdriver stop **wide open** while checking for leaks at all connections. Push fountain operator to fill chiller and remove air from tubing.

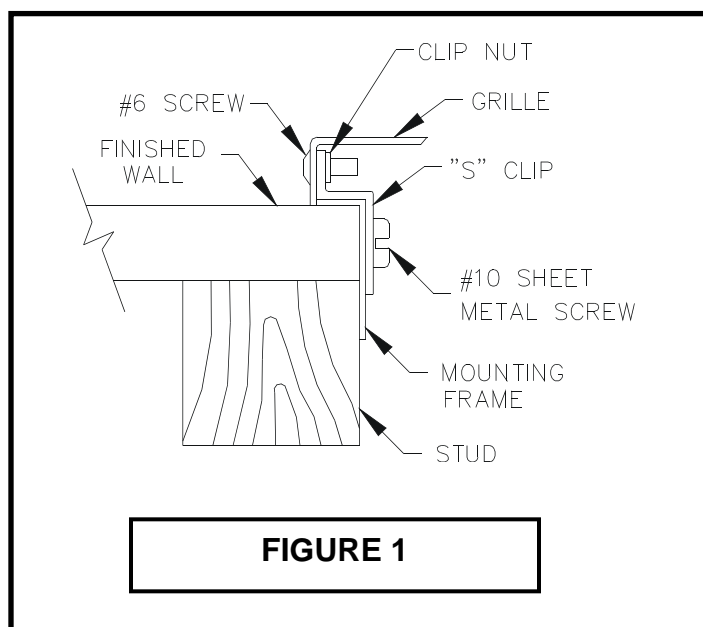

INSTALLATION PROCEDURE...

- STEP 9:** Adjust bubbler stream height using small flathead screwdriver inserted through a hole in the center of the push button for increased flow turn clockwise and for decreased flow turn counterclockwise. If flow problems arise, see troubleshooting guide for additional instructions to correct problem. Bubbler stream may lower during short break-in period. Set initial stream height a little high to minimize or eliminate the need for break-in period readjustment.
- STEP 10:** Verify that electrical power is off and power supply voltage, phase and cycle match specifications printed on chiller label. In accordance with local codes, wire directly to incoming lines at internal chiller junction box. Verify that all inner packing is removed and hand rotate fan blade to verify free rotation. Reattach chiller front panel. Turn power on and verify that chiller cycles off after water reaches proper temperature. Finally check for leaks.
- STEP 11:** Install grille and tighten outer side screws. Verify there is chilled water out of bubbler.

MAINTENANCE

- STEP 1:** Periodically clean the in strainer located inside the valve body. Refer to 5874 Series Valve Manual for more information.
- STEP 2:** The condenser fins on chiller should be periodically cleaned with brush, air hose or vacuum cleaner. Care should be taken not to bend or deform the condenser fins
- STEP 3:** The chiller temperature control is factory set for 50°F water under normal conditions. For colder water, adjust control clockwise. For warmer water, turn counterclockwise. Remove front chiller panel for access to temperature control. After adjustment allow unit to cycle off before checking outlet water temperature.

TROUBLESHOOTING	
PROBLEM	REPAIR CHECKLIST
1. Insufficient bubbler flow.	1a. Check that inlet screwdriver stop valve is in wide-open position. b. Verify minimum 30 psi flowing supply pressure. c. Clean strainer. See 5874 Series Valve Manual. d. Adjust valve to increase flow. Use front adjust screw or see 5874 Series Valve Manual.
2. Water too warm or cold.	a. Adjust chiller temperature control, clockwise for colder water.

For more information about Haws products, see our website: www.hawSCO.com

ITEM	DESCRIPTION	PART NO.
1	STRAINER ASSEMBLY	6462
2	BACK PANEL	0004023580
3	HEAD	5703M
4	BUTTON, PUSH, FLANGED, ASSY	PBA6
5	BUTTON, PUSH, FLANGED, WITH VALVE	5874PBF
6	BOTTOM PLATE (LONG)	PBM1109
7	BOTTOM PLATE (SHORT)	PBM1105
** 8	MOUNTING FRAME	MTGFR.LG
9	CHILLER	HCR8-300
10	SPANNER WRENCH	0006983506
11	GRILLE	0002626651
12	TRAP	0005982900
13	VALVE REPAIR KIT	VRK5874

** REQUIRED - SOLD SEPARATELY

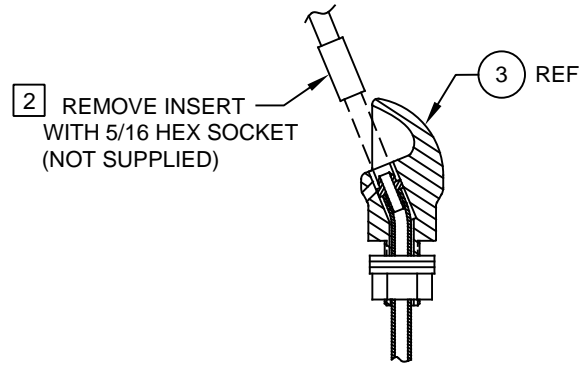
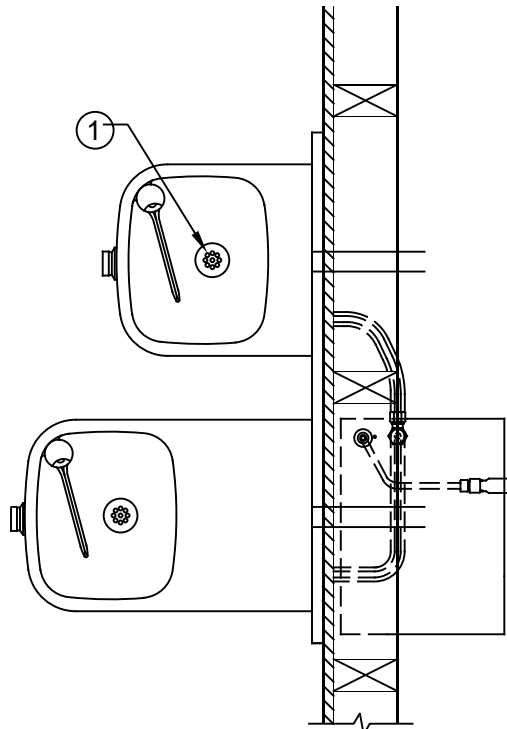

DETAIL A
ROTATED 90° INTO VIEW

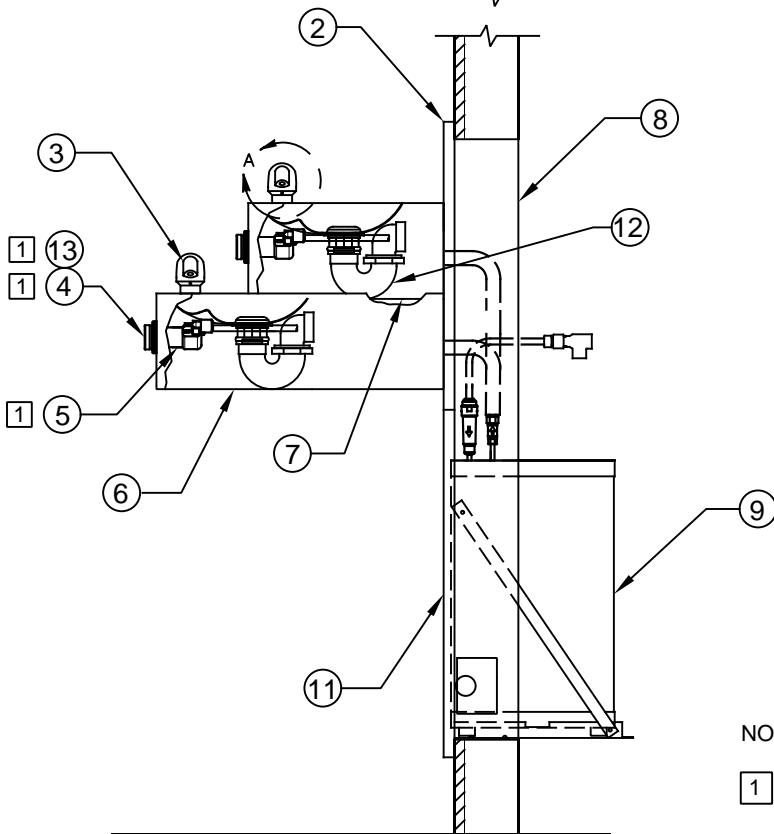

NOTES:

- 1 5874PBF (ITEM 5) INCLUDES VRK5874 CARTRIDGE ASSEMBLY (ITEM 13) AND PBA6 FLANGED PUSH BUTTON (ITEM 4).
- 2 ENSURE TUBE IS DISCONNECTED FROM PUSH BUTTON VALVE BODY PRIOR TO REMOVAL. APPLY ONE DROP OF LOCTITE 222MS TO NOZZLE THREADS PRIOR TO FASTENING BACK ONTO BUBBLER HEAD. RE-ATTACH TUBE TO VALVE.

PARTS BREAKDOWN

WHEN ORDERING PARTS PLEASE SPECIFY MODEL NUMBER.

			1455 KLEPPE LANE SPARKS, NEVADA 89431 (775) 359-4712 FAX (775) 359-7424 E-MAIL: HAWS@HAWS.CO.COM WEBSITE: WWW.HAWS.CO.COM	
			ECN NO. REVISED PER BY ECN: 5527 FV	MODEL(S) H1119.8
DRAWN DATE CHKD DP F.VASQUEZ 09-04-98	APPROVED DATE FV 04/02/20	SCALE: 1:4 DRAWING TYPE: PARTS BREAKDOWN	REVISION 22	
SIZE: A SHEET 1 OF 1				

NOTES:

1. HOLD ROUGH-IN DIMENSIONS $\pm 1/8"$ (3.2mm)
2. WHEN INSTALLING THIS UNIT, LOCAL, STATE OR FEDERAL CODES SHOULD BE ADHERED TO. FOR INSTALLATION HEIGHTS OTHER THAN SHOWN, DIMENSIONS MARKED (*) MUST BE ADJUSTED ACCORDINGLY.
3. ALIGN HOLES IN CHILLER SUPPORT TRAY WITH HOLES IN FRAME AND FASTEN WITH #10 SHEET METAL SCREWS.
4. REFER TO 5874 SERIES OPERATION AND MAINTENANCE MANUAL FOR PUSH BUTTON AND VALVE INSTALLATION/MAINTENANCE INSTRUCTIONS.
5. REFER TO MTGFR.LG INSTALLATION DRAWING FOR ROUGH-IN DIMENSIONS.
6. INSERT 5/16"-18 PANEL INSERTS FROM OPPOSITE SIDE AT LOCATIONS SHOWN BY DARKENED HOLES. HOLE COMBINATIONS SHOWN ARE FOR USE WITH LOW FOUNTAIN ON THE RIGHT AND THE HI FOUNTAIN ON THE LEFT. USE OPPOSITE HOLES FOR HI ON RIGHT AND LOW ON LEFT.
7. HOLE COMBINATION SHOWN BELOW IS FOR USE WITH LOW FOUNTAIN ON THE RIGHT AND HIGH FOUNTAIN ON THE LEFT. USE OPPOSITE HOLES FOR HIGH ON RIGHT AND LOW ON LEFT.
8. TO CHANGE FOUNTAIN MTG. SCREW LOCATIONS: FIRST REMOVE SCREWS AND THEN SQUEEZE CLIPS ON NUT RETAINER TO POP OUT. SNAP INTO NEW POSITIONS AND RE-ASSEMBLE SCREWS.
9. IMPORTANT: A L.H. LOW (OPTIONAL) CONFIGURATION WILL REQUIRE A DIFFERENT BACK PANEL AND THE WASTE AND SUPPLY DIMENSIONS SHOWN (*) MUST BE REVERSED.

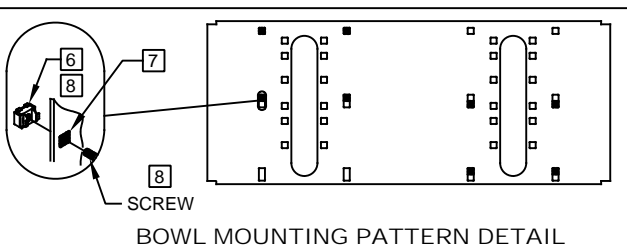
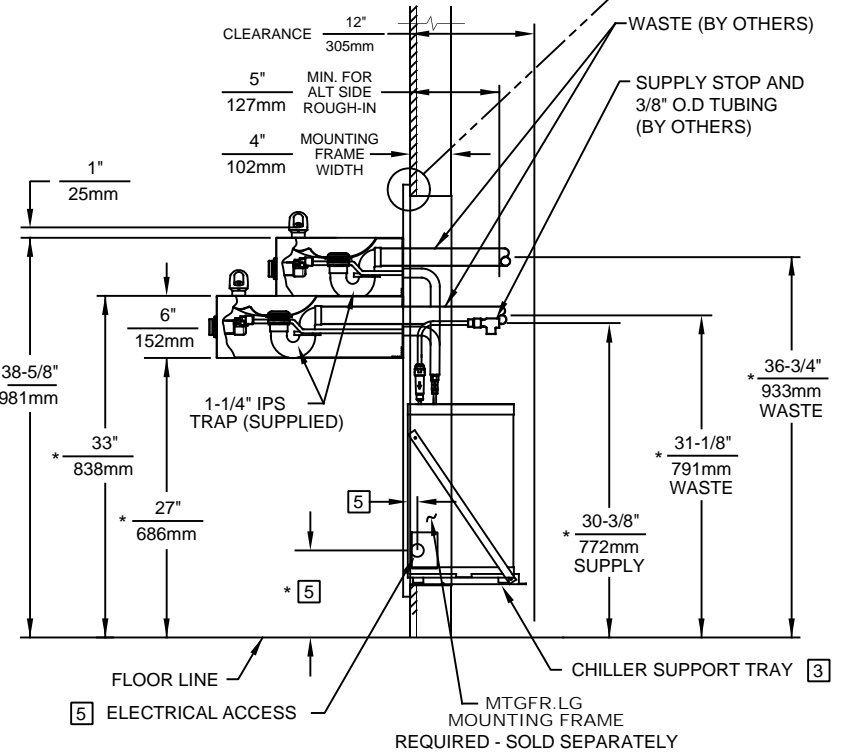
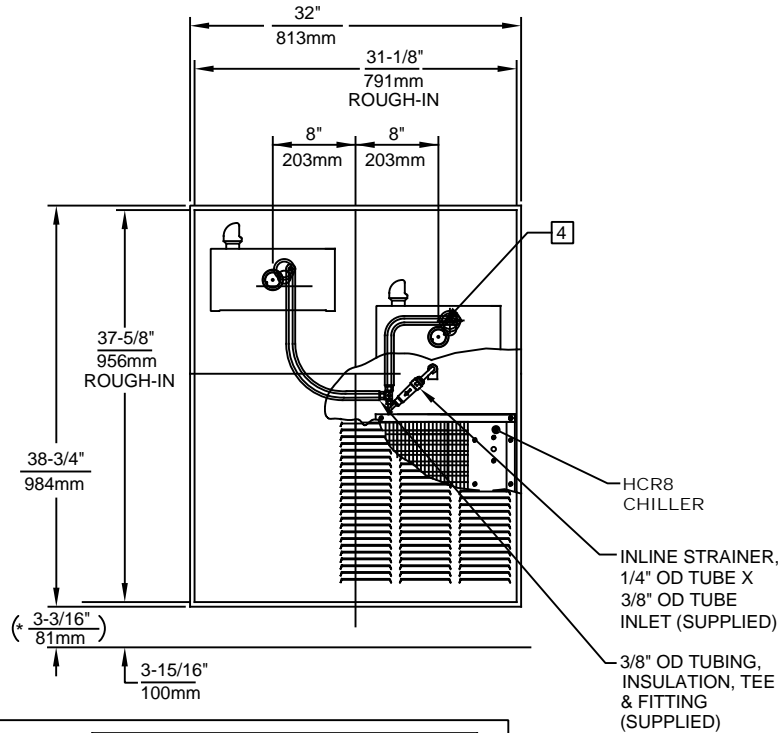
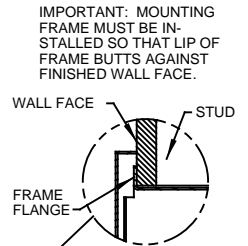
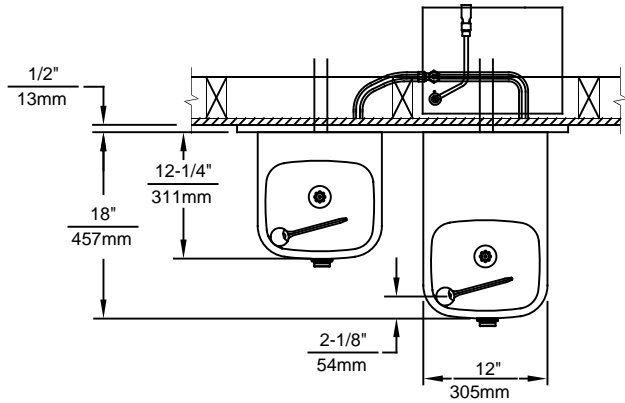

1455 KLEPPE LANE
SPARKS, NEVADA 89431
(775) 359-4712 FAX (775) 359-7424
E-MAIL: HAWS@HAWS.CO.COM
WEBSITE: WWW.HAWS.CO.COM

ECN NO. REVISED PER BY:		MODEL(S)		PART NUMBER	
ECN: 5527 FV		H1119.8		0002080262.D	
DRAWN:	DATE:	CHKD.:	REVISION		
F.VASQUEZ	09-01-98	DP	22		
APPROVED:	DATE:	SCALE:	DRAWING TYPE:	INSTALLATION	SIZE: A SHEET 1 OF 1
FV	04/02/20	1:19	INSTALLATION		