



INSTALLATION, OPERATION & MAINTENANCE INSTRUCTIONS

1455 Kleppe Lane ♦ Sparks, NV 89431-6467 ♦ (775) 359-4712 ♦ Fax (775) 359-7424
E-mail: haws@hawsco.com ♦ website: www.hawsco.com

No. 0002080203 (25)

Model 9001EXP Alarm

NOTE TO INSTALLER: Please leave this information with the Maintenance Department.

LIMITED WARRANTY

HAWS warrants that this specific product is guaranteed against defective material or poor workmanship for a period of **one year from date of shipment**. HAWS liability under this warranty shall be discharged by furnishing without charge F.O.B. HAWS Factory any goods, or part thereof, which shall appear to the Company upon inspection to be of defective material or not of first class workmanship, provided that claim is made in writing to Haws within a reasonable period after receipt of the product. Where claims for defects are made, the defective part or parts shall be delivered to the Company, prepaid, for inspection. HAWS will not be liable for the cost of repairs, alterations or replacements, or for any expense connected therewith made by the owner or his agents, except upon written authority from HAWS, Sparks, Nevada. HAWS will not be liable for any damages caused by defective materials or poor workmanship, except for replacements, as provided above. Buyer agrees that Haws has made no other warranties either expressed or implied in addition to those above stated, except that of title with respect to any of the products or equipment sold hereunder and that HAWS shall not be liable for general, special, or consequential damages claimed to arise under the contract of sale.

The emergency equipment manufactured by HAWS is warranted to function if installation and maintenance instructions provided are adhered to. The units also must be used for the purpose for which they were intended. This product is intended to supplement first-aid treatment. Due to widely varying conditions, Haws cannot guarantee that the use of this emergency equipment will prevent serious injury or the aggravation of existing or prior injuries.

NO OTHER WARRANTIES EXPRESSED OR IMPLIED ARE AUTHORIZED, PROVIDED OR GIVEN BY HAWS.

SHOULD YOU EXPERIENCE DIFFICULTY WITH THE INSTALLATION OF THIS MODEL PLEASE CALL:

TECHNICAL SUPPORT: 1-800-766-5612

FOR CUSTOMER SERVICE: 1-888-640-4297

RECOMMENDED TOOLS: Pipe joint sealant, screwdriver, pipe wrench, 14 AWG wire, 3/4" conduit and basic electricians' tools for power connection.

LOCATION OF UNIT: The Model 9001EXP Alarm may be mounted directly to the upper stand pipe of a safety shower or wall mounted next to a shower or eyewash. The alarm should be clearly visible from several directions.

ELECTRICAL SUPPLY: 120 VAC 50/60 HZ, 20 Watts average power consumption. Suitable for use in Class I, Division 2, Group B, C, D areas; Temperature rating T2C (230°C) with 60 Watt lamp /T2A (280°C) with 100 Watt lamp. Unit supplied with 8 Watt LED lamp. **WARNING:** Power shall be supplied by a dedicated circuit through a **10 AMP maximum** breaker or fuse and should not supply any power to any other devices.

WATER SUPPLY: The flow switch requires a minimum of 2.4 GPM to activate. Mount flow switch in supply line with flow in horizontal direction and switch stem extending vertically from tee. Mount switch with at least 6" of straight pipe on both sides to minimize turbulence in switch.

TROUBLESHOOTING	
PROBLEM	REPAIR CHECKLIST
1. Alarm horn and light do not operate.	1a. Check incoming circuit for power and power from flow switch. b. Check that the direction of water flow corresponds to the arrow on the flow switch body. c. Check that water flow is sufficient. d. Check all electrical connections for security, including those in alarm base. e. Faulty flow switch. Replace entire switch assembly. f. Faulty flasher module in alarm. Replace flasher module.
2. Horn sounds but light does not flash.	2a. Only replace lamp with Haws P/N 0003225505. (See sheet 2 of installation drawing) b. Should replacement lamp also fail to operate, replace flasher module.
3. Lamp replacement.	3a. Remove the guard from the light fixture, and then unscrew the glass lens to replace the lamp. Only replace lamp with Haws P/N 0003225505. (See sheet 2 of installation drawing)
4. Alarm stays on.	4a. Check wiring connections. b. Disconnect flow switch wires and test for continuity.

INSTALLATION PROCEDURE

***WARNING: EXPLOSION HAZARD – SUBSTITUTION OF COMPONENTS MAY IMPAIR SUITABILITY FOR CLASS 1, DIVISION 2**

- STEP 1:** Choose a location for mounting the flow switch in the water supply line. The inlet and outlet ports of the flow switch must be a minimum of 6 inches from any tees or elbows in the water supply line. See attached installation drawing.
- STEP 2:** Mount the flow switch assembly in the water supply line. The switch body must be in the vertical position with the water pipe horizontal. The water flow must be in the direction marked by the arrow on the flow switch body. Use pipe sealing compound on all water pipe connections.
- STEP 3:** Choose a location for mounting the alarm assembly. The alarm housing should be positioned along a vertical axis at least 7 feet above ground for best visibility. The alarm may be mounted directly to a water pipe using the supplied bracket, U-bolt, washers and nuts. The alarm can also be bolted to a flat surface such as a wall, using the supplied wall-mounting bracket with appropriate fasteners (not supplied).
- STEP 4:** Connect power to terminal blocks 1 and 2 for the alarm. Terminal blocks 5 and 6 may be used for remote alarm actuation. Refer to wiring diagram on installation drawing.

NOTICE:

ALL POWER CONNECTIONS MUST BE MADE ACCORDING TO NEC CODE USING TYPE 4 AND CLASS 1 DIVISION 2 COMPLIANT EQUIPMENT.

OPERATION AND TEST INSTRUCTIONS

Test weekly. Instruct all employees in the use of emergency showers and eyewashes.

- STEP 1:** Apply power to the alarm branch circuit. The alarm should remain OFF.
- STEP 2:** Open the shower or eyewash flow valve. The alarm should sound and the light should flash shortly after water flows from the system.
- STEP 3:** Shut off the flow valve. The light and horn should turn off.

For more information about Haws products see our website: www.hawasco.com

PARTS BREAKDOWN

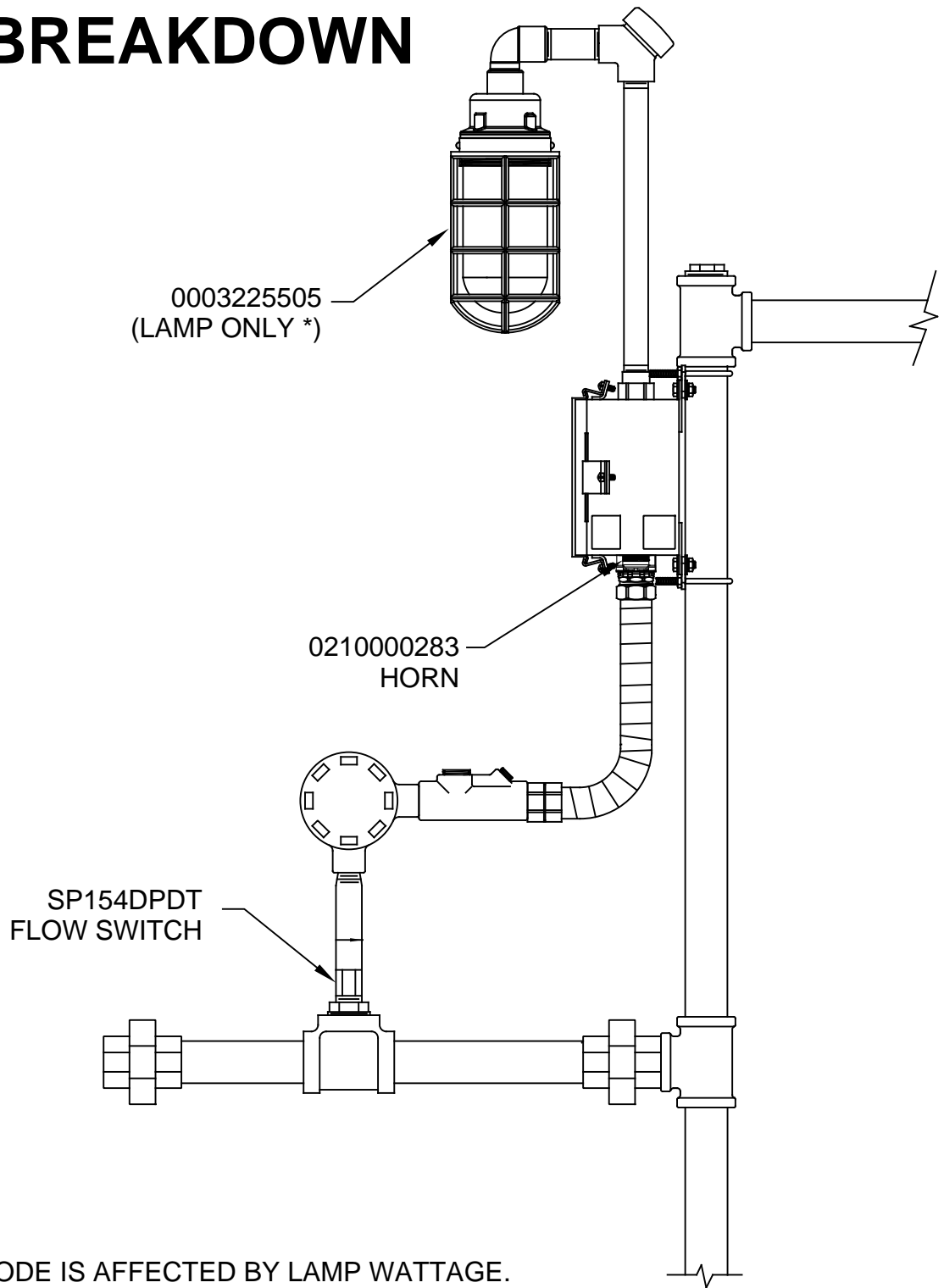

* TEMPERATURE CODE IS AFFECTED BY LAMP WATTAGE.
60 WATT LAMP YIELDS T2C (230 DEG C), 150 WATT
YIELDS T2 (300 DEG C). SUPPLIED LAMP IS 8 WATT LED.



Haws®

1455 KLEPPE LANE
SPARKS, NEVADA 89431
(775) 359-4712 FAX (755) 359-7424
E-MAIL: HAWS@HAWSO.COM
WEBSITE: WWW.HAWSO.COM

ECN NO.	REVISED PER	BY
	ECN: 5438	DP
DRAWN	DATE	CHKD
CLF	3/17/93	
APPROVED	DATE	
IR	12/09/19	

MODEL(S)

9001EXP

PART NUMBER	
0002080203	
DRAWING NO.	REV
A	25

WHEN ORDERING PARTS PLEASE SPECIFY MODEL NUMBER.

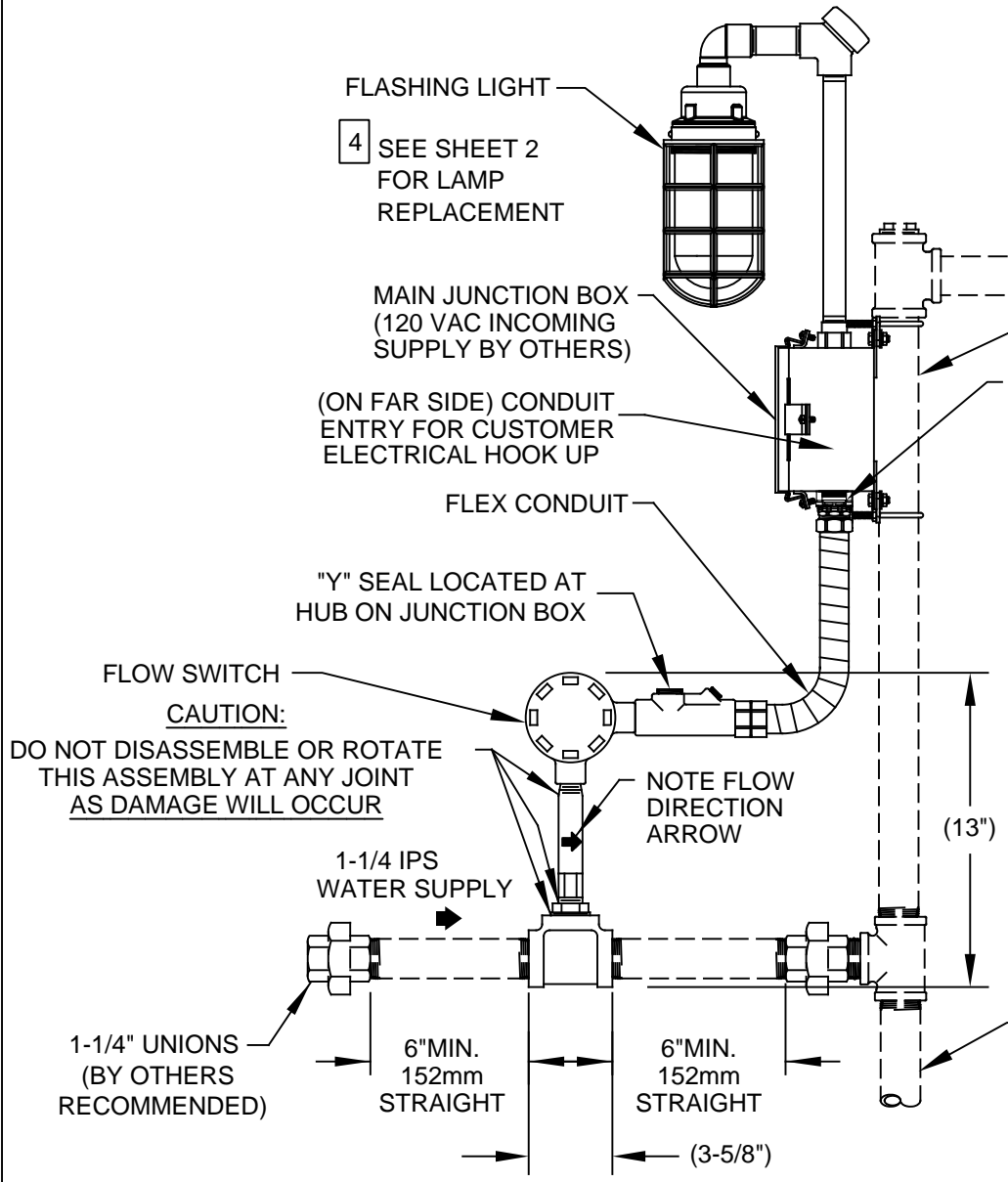

CAUTION:
DO NOT DISASSEMBLE OR ROTATE THIS ASSEMBLY AT ANY JOINT AS DAMAGE WILL OCCUR

4 SEE SHEET 2 FOR LAMP REPLACEMENT

NOTES:

1. AUDIBLE AND VISIBLE ALARM ACTIVATED WHEN SHOWER OR EYEWASH IS IN USE.
2. 120VAC SUPPLY VOLTAGE REQUIRED, APPROXIMATELY 100VA ALL ELECTRICAL HOOKUPS TO MAIN JUNCTION BOX.
3. SYSTEM CERTIFIED AS SUITABLE FOR CLASS I, DIV. 2 GROUPS B, C, D LOCATION INSTALLATION. INSTALLER MUST USE THREAD SEALANT, SUCH AS APPLETON TLC3, RECOMMENDED FOR USE IN HAZARDOUS LOCATIONS ON ALL ELECTRICAL NPT CONNECTIONS.

(CONTINUED ON SHEET 2)

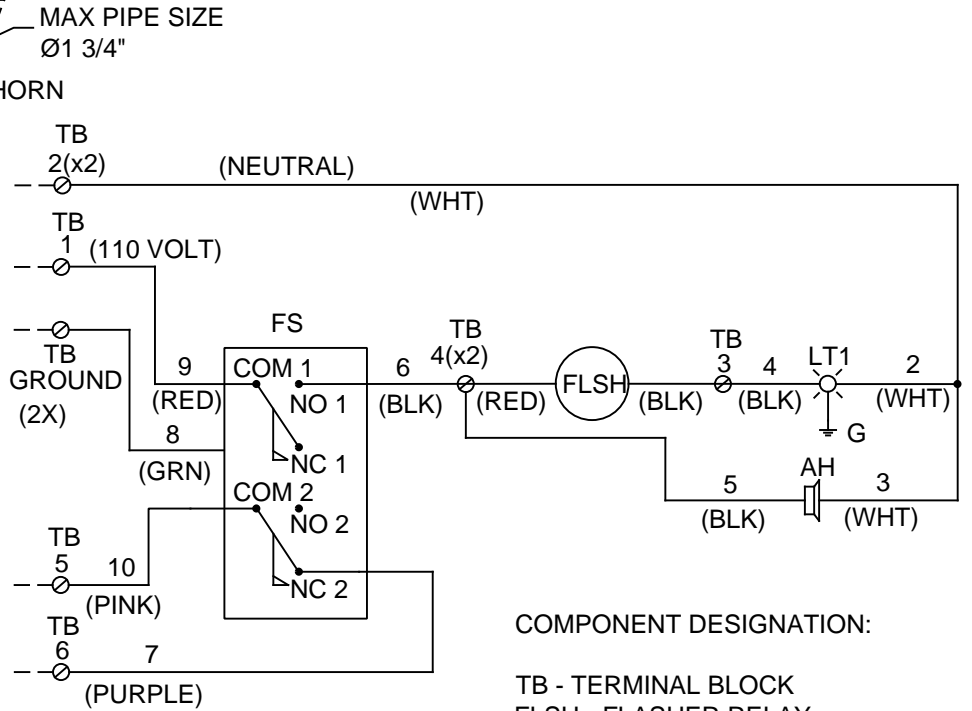

COMPONENT DESIGNATION:

- TB - TERMINAL BLOCK
- FLSH - FLASHER RELAY
- LT1 - RED LIGHT
- FS - FLOW SWITCH
- AH - ALARM HORN

SWITCH MUST BE MOUNTED IN HORIZONTAL POSITION

		1455 KLEPPE LANE SPARKS, NEVADA 89431 (775) 359-4712 FAX (775) 359-7424 E-MAIL: HAWS@HAWS.CO.COM WEBSITE: WWW.HAWS.CO.COM	
ECN NO. REVISED PER BY: ECN: 5438 DP	MODEL(S)	9001EXP	PART NUMBER 0002080203.D
DRAWN: C.J.L. DATE: 06/91 CHK'D:			DRAWING NO. 09648A00 REV 25
APPROVED: IR DATE: 12/09/19	SCALE: 1:1	DRAWING TYPE: INSTALLATION	SHEET 1 OF 2

NOTES: (CONTINUED FROM SHEET 1)

4 LIGHT REPLACEMENT INSTRUCTIONS:

- 1) REMOVE GUARD AND GLOBE:
FIRST LOOSEN SET SCREW (LOCATED ON GUARD WHERE SHOWN). NEXT, ROTATE GUARD COUNTER CLOCKWISE UNTIL GUARD IS FREE. FINALLY ROTATE GLOBE COUNTER CLOCKWISE UNTIL GLOBE IS FREE AND LAMP IS EXPOSED.
- 2) ONLY REPLACE LAMP WITH HAWS P/N 0003225505.
WARNING - EXPLOSION HAZARD - SUBSTITUTION OF COMPONENTS MAY IMPAIR SUITABILITY FOR CLASS 1, DIVISION 2.
- 3) REPLACE GUARD AND GLOBE:
ROTATE GLOBE CLOCKWISE ONTO THREADS UNTIL SEALED AGAINST GASKET. NEXT, ROTATE GUARD CLOCKWISE ONTO THREADS UNTIL TIGHT. FINALLY TIGHTEN SET SCREW.

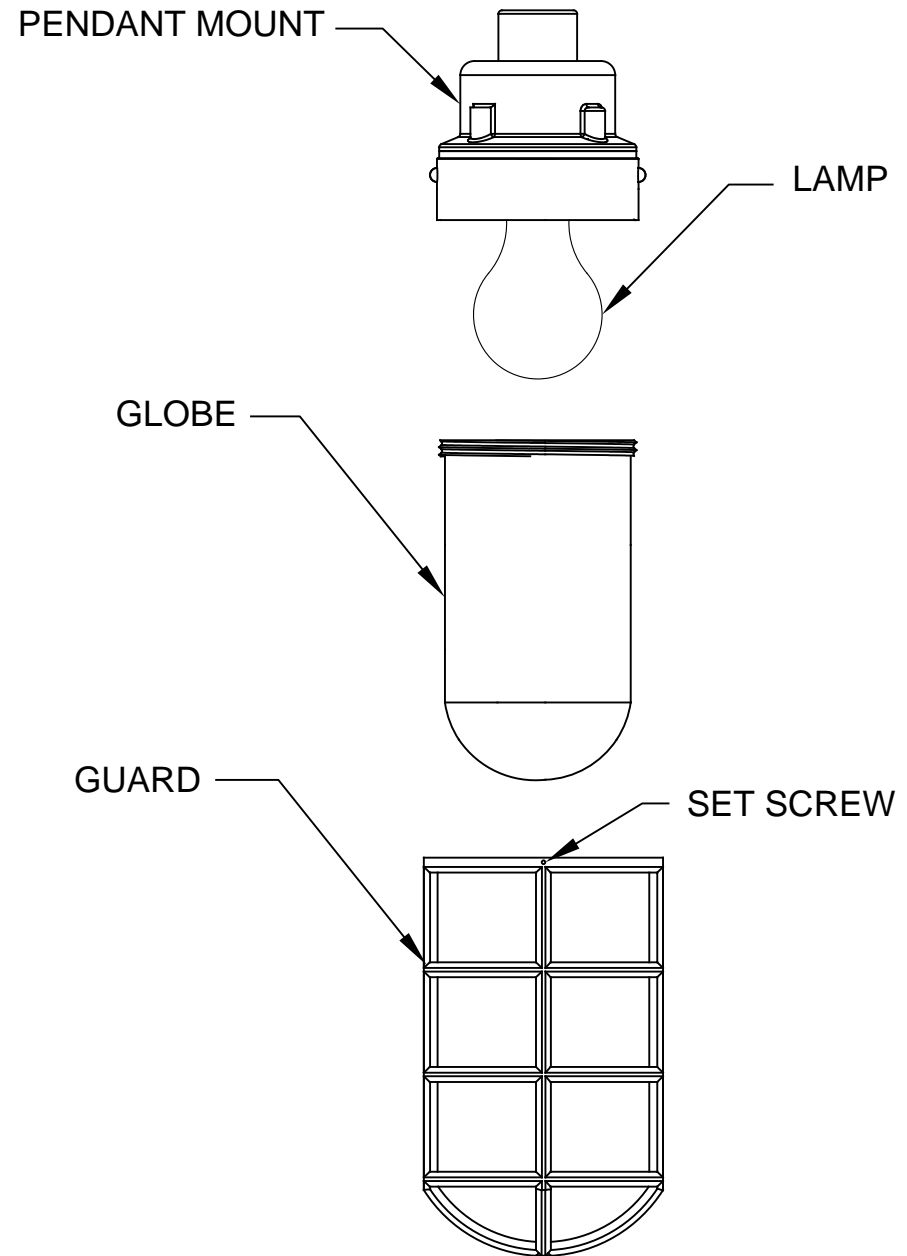

			Haws [®]			1455 KLEPPE LANE SPARKS, NEVADA 89431 (775) 359-4712 FAX (755) 359-7424 E-MAIL: HAWS@HAWS.CO.COM WEBSITE: WWW.HAWS.CO.COM		
ECN NO.	REVISED PER	BY:	MODEL(S)	9001EXP		PART NUMBER		
	ECN: 5438	DP				0002080203.D		
DRAWN:	DATE:	CHK'D.:				DRAWING NO.	REV	
HM	08/12/09					09468A00	25	
APPROVED:	DATE:	SCALE:	DRAWING TYPE:	INSTALLATION	SIZE:	SHEET 2 OF 2		
IR	12/09/19	1:1			A			