



INSTALLATION, OPERATION & MAINTENANCE INSTRUCTIONS

1455 Kleppe Lane ♦ Sparks, NV 89431-6467 ♦ (775) 359-4712 ♦ Fax (775) 359-7424
E-mail: haws@hawsco.com ♦ website: www.hawsco.com

No. 0002080078 (4)

Model 7655WCC Eye/face Wash

NOTE TO INSTALLER: Please leave this information with the Maintenance Department.

LIMITED WARRANTY

HAWS warrants that all of its products are guaranteed against defective material or poor workmanship for a period of **one year from the date of shipment**. The foregoing notwithstanding, *HAWS* warrants certain specific products or components thereof for an adjusted period. A list of these excepted products and components and a description of their respective warranty terms may be found here: www.hawsco.com/warranty. *HAWS*' liability under this warranty shall be discharged by furnishing without charge F.O.B. *HAWS* factory any goods, or part thereof, which shall appear to the Company upon inspection to be of defective material or not of first-class workmanship, provided that a claim is made in writing to Company within a reasonable period after receipt of the product. Where claims for defects are made, the defective part or parts shall be delivered to the Company, prepaid, for inspection. *HAWS* shall not be liable for the cost of repairs, alterations or replacements, or the labor required to implement them, or for any expense connected therewith made by the owner or owner's agents, except upon written authority from *HAWS*. *HAWS* shall not be liable for any damages caused by defective materials or poor workmanship, except for replacements, as provided above. Buyer agrees that *HAWS* has made no other warranties either express or implied in addition to those above stated, except that of title with respect to any of the products or equipment sold hereunder and that *HAWS* shall not be liable for general, special, incidental, or consequential damages claimed to arise under the contract of sale.

Equipment manufactured by *HAWS* is warranted to function if installation and maintenance instructions provided are adhered to. The units also must be used for the purpose for which they were intended. Any *HAWS* emergency equipment is intended to supplement first-aid treatment. Due to widely varying conditions, *HAWS* cannot guarantee that the use of this emergency equipment will prevent serious injury or the aggravation of existing or prior injuries.

EXCEPT AS EXPRESSLY STATED HEREIN, HAWS HEREBY DISCLAIMS ALL WARRANTIES, WHETHER EXPRESS OR IMPLIED, ARISING BY LAW OR OTHERWISE, INCLUDING WITHOUT LIMITATION, ANY IMPLIED WARRANTIES OF MERCHANTABILITY AND FITNESS FOR A PARTICULAR PURPOSE. THIS WARRANTY MAY NOT BE MODIFIED OR EXTENDED WITHOUT THE WRITTEN CONSENT OF HAWS. REMEDIES AND REPLACEMENTS STATED HEREIN ARE EXCLUSIVE. IN NO EVENT SHALL HAWS BE LIABLE FOR ANY SPECIAL, PUNITIVE, CONSEQUENTIAL OR INCIDENTAL DAMAGES TO ANY PERSON INCLUDING BUT NOT LIMITED TO DAMAGES FOR LOSS OF USE OR PROFITS, SUBSTITUTE PRODUCTS OR COSTS, PROPERTY DAMAGE, OR OTHER MONETARY LOSS.

SHOULD YOU EXPERIENCE DIFFICULTY WITH THE INSTALLATION OF THIS MODEL PLEASE CALL:

TECHNICAL SUPPORT: 1-800-766-5612
FOR CUSTOMER SERVICE: 1-888-640-4297

RECOMMENDED TOOLS: Adjustable wrench, pipe wrench, pipe joint sealant, Phillips screwdriver, ¼" hex key wrench.

LOCATION OF UNIT: The Model 7655WCC eye/face wash should be installed in close proximity to potential accident areas. It should be clearly identified free from obstructions and easy to access. See ANSI Z358.1 guidelines for more information.

SUPPLY LINE: The minimum recommended line size is 1/2" IPS with 30-90 psi (2-6 ATM) flowing pressure at supply inlet. Where sediment or mineral content is a problem, an inlet filter is recommended.

PLUMBING CONNECTIONS: Inlet supply is male 1/2" IPS, no drain.

CLEANING INSTRUCTIONS FOR STAINLESS ELECTROPOLISH PRODUCTS

Haws recommended cleaning procedure for stainless electropolish products is as follows:

1. Use a stainless-steel polish and cleaner for removing stains and fingerprints.
2. Spray cleaner onto stainless surfaces and wipe dry with clean cloth.

INCLUDED PARTS

MODEL PACKAGE	QUANTITY	ITEMS INCLUDED
7655WCC	1	Mounting Frame/Eyewash assembly
	1	Emergency Eyewash Sign
	1	Test Tag

TROUBLESHOOTING

PROBLEM	REPAIR CHECKLIST
1. No flow.	1a. Check the main shut-off valve.
2. Insufficient water flow at eye/face wash.	2a. Verify minimum 30 psi (2 ATM) flowing supply line pressure. b. Probable clogging of flow control due to inadequate line flushing. Unscrew eye/face wash head and remove the four screws to disassemble head. Clean flow control and reassemble head. c. Remove cap located on L – Strainer using a 1/4" Allen wrench to access and clean filter screen.
3. Eye/face wash streams do not meet desired eye level.	3a. Possible blocked flow control, see above solution. b. Possible non-leveled eye/face wash assembly.

For more information about Haws products, see our website: www.hawesco.com.

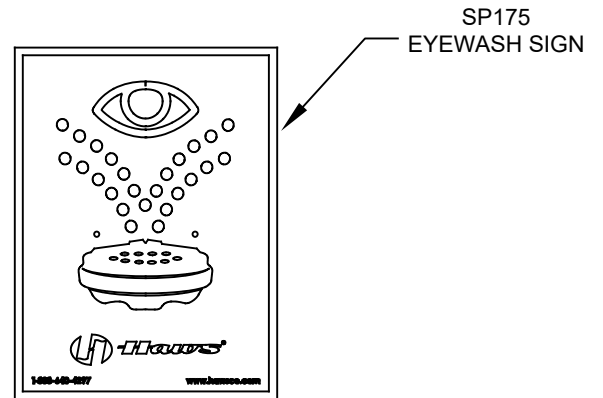
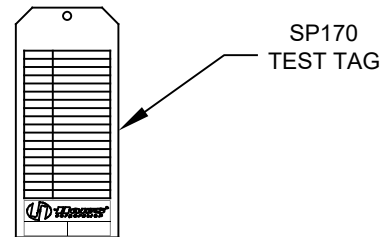
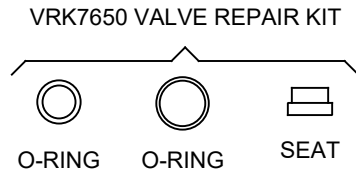
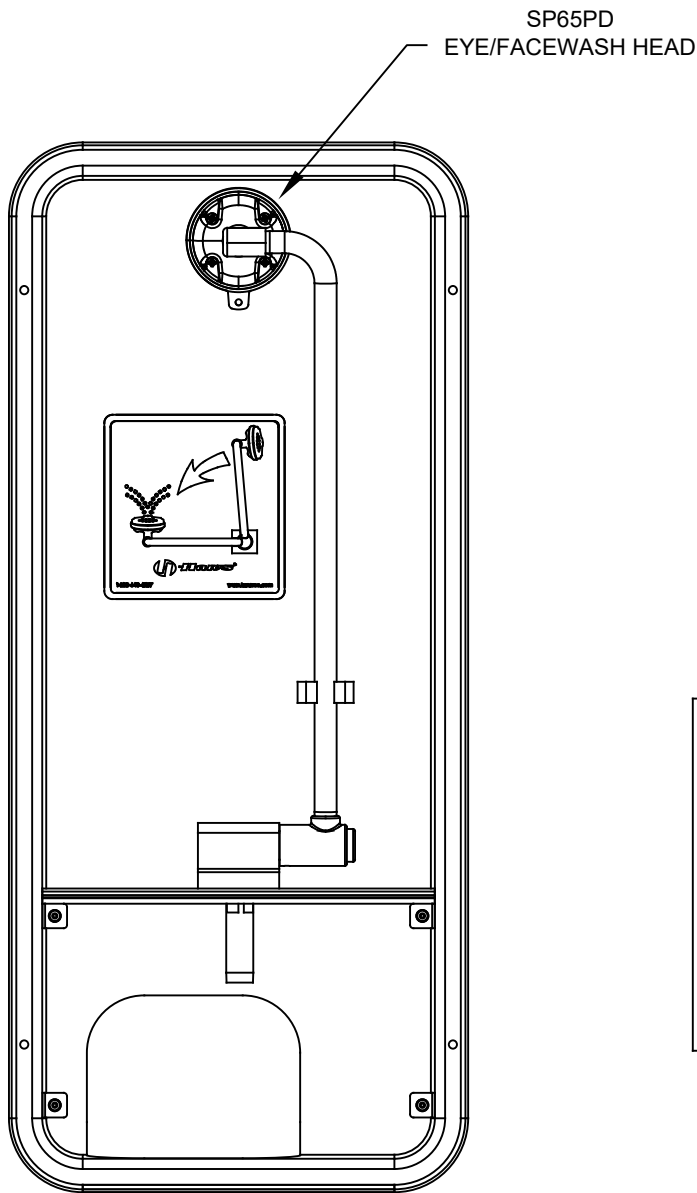

PARTS BREAKDOWN

WHEN ORDERING PARTS PLEASE SPECIFY MODEL NUMBER.

		Haws [®]		1455 KLEPPE LANE SPARKS, NEVADA 89431 (775) 359-4712 FAX (775) 359-7424 E-MAIL: HAWS@HAWS.CO.COM WEBSITE: WWW.HAWS.CO.COM			
				ECN NO. 4290 DRAWN IR APPROVED FV	REVISED PER ECN: 5752 DATE 8/4/10 DATE 10/19/21	BY FV CHKD JL	MODEL(S) 7655WCC
		SCALE: NA		DRAWING TYPE: PARTS BREAKDOWN		SIZE: A	SHEET 1 OF 1

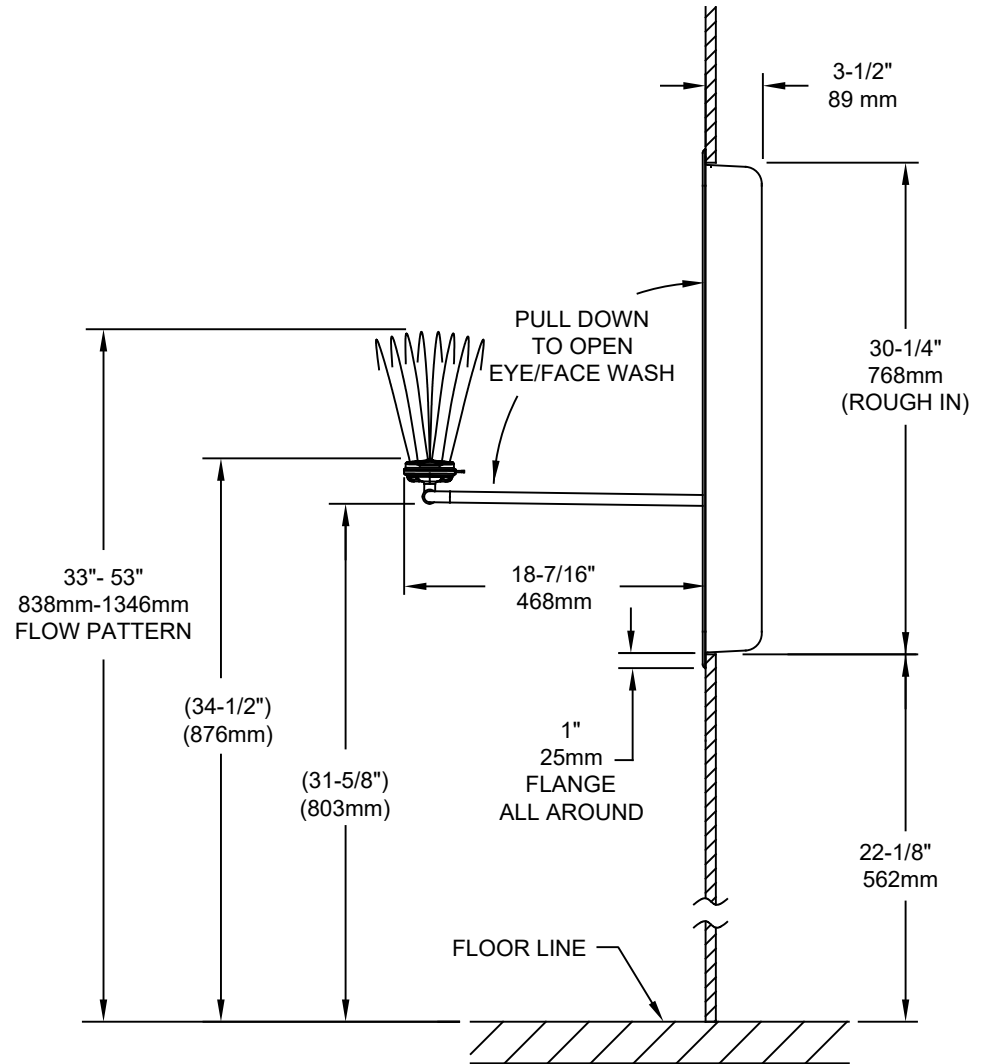
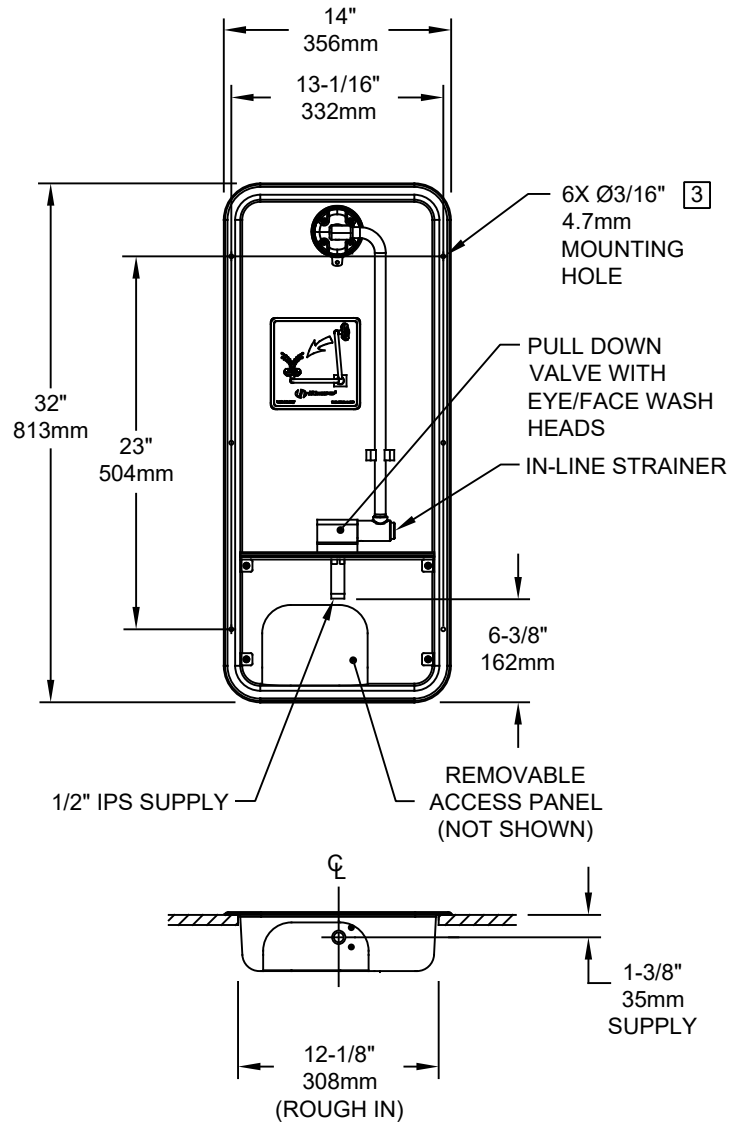

- NOTES:
1. WHEN INSTALLING THIS UNIT, LOCAL, STATE, OR FEDERAL CODES SHOULD BE ADHERED TO FOR INSTALLATION DIMENSIONS (LOCATIONS), WASTE AND SUPPLY REQUIREMENTS OTHER THAN SHOWN.
 2. TO COMPLY WITH ANSI Z358.1-2014 FOR EMERGENCY EYEWASH OR EYE/FACE WASH: EYEWASH OR EYE/FACE WASH SHALL BE POSITIONED SUCH THAT FLUSHING FLUID PATTERN IS NOT LESS THAN 33" (838mm) AND NO GREATER THAN 53" (1346mm) FROM SURFACE ON WHICH USER STANDS; AND 6.0" (153mm) MINIMUM FROM WALL OR NEAREST OBSTRUCTION.
 - 3 MOUNTING HARDWARE NOT SUPPLIED.
 4. DIMENSIONS MAY VARY BY ±1/2" (13 mm).



1455 KLEPPE LANE
SPARKS, NEVADA 89431
(775) 359-4712 FAX (775) 359-7424
E-MAIL: HAWS@HAWSCO.COM
WEBSITE: WWW.HAWSCO.COM

ECN NO. 4290	REVISED PER ECN: 5752	BY: FV	MODEL(S) 7655WCC	PART NUMBER 0002080078.D
DRAWN: IR	DATE: 8/4/10	CHK'D: JL		REVISION 4
APPROVED: FV	DATE: 10/19/21	SCALE: NA	DRAWING TYPE: INSTALLATION	SIZE: A SHEET 1 OF 1