



INSTALLATION, OPERATION & MAINTENANCE INSTRUCTIONS

1455 Kleppe Lane ♦ Sparks, NV 89431-6467 ♦ (775) 359-4712 ♦ Fax (775) 359-7424
E-mail: haws@hawsco.com ♦ website: www.hawsco.com

No. 0002077820 (18)

Model 6521FR

NOTE TO INSTALLER: Please leave this information with the Maintenance Department.

LIMITED WARRANTY

HAWS warrants that all of its products are guaranteed against defective material or poor workmanship for a period of **one year from the date of shipment**. The foregoing notwithstanding, *HAWS* warrants certain specific products or components thereof for an adjusted period. A list of these excepted products and components and a description of their respective warranty terms may be found here: www.hawsco.com/warranty. *HAWS*' liability under this warranty shall be discharged by furnishing without charge F.O.B. *HAWS* factory any goods, or part thereof, which shall appear to the Company upon inspection to be of defective material or not of first-class workmanship, provided that a claim is made in writing to Company within a reasonable period after receipt of the product. Where claims for defects are made, the defective part or parts shall be delivered to the Company, prepaid, for inspection. *HAWS* shall not be liable for the cost of repairs, alterations or replacements, or the labor required to implement them, or for any expense connected therewith made by the owner or owner's agents, except upon written authority from *HAWS*. *HAWS* shall not be liable for any damages caused by defective materials or poor workmanship, except for replacements, as provided above. Buyer agrees that *HAWS* has made no other warranties either express or implied in addition to those above stated, except that of title with respect to any of the products or equipment sold hereunder and that *HAWS* shall not be liable for general, special, incidental, or consequential damages claimed to arise under the contract of sale.

Equipment manufactured by *HAWS* is warranted to function if installation and maintenance instructions provided are adhered to. The units also must be used for the purpose for which they were intended. Any *HAWS* emergency equipment is intended to supplement first-aid treatment. Due to widely varying conditions, *HAWS* cannot guarantee that the use of this emergency equipment will prevent serious injury or the aggravation of existing or prior injuries.

EXCEPT AS EXPRESSLY STATED HEREIN, HAWS HEREBY DISCLAIMS ALL WARRANTIES, WHETHER EXPRESS OR IMPLIED, ARISING BY LAW OR OTHERWISE, INCLUDING WITHOUT LIMITATION, ANY IMPLIED WARRANTIES OF MERCHANTABILITY AND FITNESS FOR A PARTICULAR PURPOSE. THIS WARRANTY MAY NOT BE MODIFIED OR EXTENDED WITHOUT THE WRITTEN CONSENT OF HAWS. REMEDIES AND REPLACEMENTS STATED HEREIN ARE EXCLUSIVE. IN NO EVENT SHALL HAWS BE LIABLE FOR ANY SPECIAL, PUNITIVE, CONSEQUENTIAL OR INCIDENTAL DAMAGES TO ANY PERSON INCLUDING BUT NOT LIMITED TO DAMAGES FOR LOSS OF USE OR PROFITS, SUBSTITUTE PRODUCTS OR COSTS, PROPERTY DAMAGE, OR OTHER MONETARY LOSS.

SHOULD YOU EXPERIENCE DIFFICULTY WITH THE INSTALLATION OF THIS MODEL PLEASE CALL:

TECHNICAL SUPPORT: 1-800-766-5612
FOR CUSTOMER SERVICE: 1-888-640-4297

RECOMMENDED TOOLS: Screwdriver, level, 12" adjustable wrench, 10" pipe wrench, 5/16", 3/4", 9/16", 1/2" and 7/16" open end wrenches.

LOCATION OF UNIT: Installed indoors only on the inside wall, and where the temperature does not go below 50°F. Used with single bubbler wall mounted fountains only. The waste and supply heights should be taken from the installation instruction sheet of the fountain.

SUPPLY LINE: The minimum recommended line size is 1/2" IPS with 30-90 psi (2-6 ATM). Where sediment or mineral content in water is a problem, an inlet filter is recommended.

PLUMBING CONNECTIONS: Inlet valve is 1/2 NPT (F). Waste trap outlet is female 1-1/4" NPT.

INSTALLATION PROCEDURE

GENERAL NOTES:

1. For all plastic push-in type fitting connections, only connect NSF-61 copper or plastic tubing. Stainless steel or glass tubing is not recommended. The following assembly instructions must be followed to ensure a watertight connection:
 - a. Cut tubing square and clean.
 - b. Mark from end of tube the length of insertion (See table below).
 - c. Push tube into the fitting until it bottoms out.
 - d. To remove, depress collet and pull tubing out.

Tube Sizes	O.D. Tolerance	Insertion Depth
3/8"	±.005"	3/4"

Refer to Installation Drawing for installation. Use pipe joint sealant on all water connections.

STEP 1: Locate and mount the fountain on wall in desired location per Installation Drawing shipped with fountain. Attach waste bend to underside of fountain and mark center of tube on wall, drill 2-1/2" hole through wall at mark. Then locate and drill 1/2" diameter hole and 1- 3/8" diameter hole through the wall (as shown on Installation Drawing).

STEP 2: Mount freeze-proof cabinet on backside of wall so that waste, supply and operating holes in cabinet line up with holes drilled through wall. Then cut and thread 1-1/4" nipple long enough to allow the waste bend to enter the nipple and the 1-1/4" slip-joint nut and washer to be tightened fully on the fountain side. The nipple must be long enough to be threaded into the 1-1/4" NPT elbow in cabinet (see view A on Installation Drawing).

INSTALLATION PROCEDURE

- STEP 3:** Snap in 1/8" bushing (provided) before feeding the 1/8" tubing through the 1/8" IPS pipe sleeve (not provided) (see view C on Installation Drawing) then attach to the push button and secure with the compression nut hand tight only. Bend the 3/8" copper tubing (provided) into appropriate hole and insert through the 1" IPS pipe sleeve (not provided) from the cabinet side (see view B on Installation Drawing). Connect tubing to drain valve fitting in cabinet and measure, cut and connect tubing to bubbler. Be sure the tubing has a uniform slope downward from the bubbler to the fitting on top of the drain valve. Avoid low spots, which might collect water causing ice plugs in freezing weather.
- STEP 4:** Flush the incoming water supply line before hook-up and install a shut-off valve (not supplied).
- STEP 5:** Insert 1/2" IPS pipe supply (not supplied) through side of box and attach to 1/2" NPT elbow (supplied). Insert 1-1/4" IPS waste pipe (not supplied) through the side of box and attach the 1-1/4" elbow of the trap assembly.
- STEP 6:** Turn on the shut-off valve (not supplied) and check for leaks. Push the operator button on and check for leaks. When the button is released the control valve should turn off and the drain valve should open and allow the 3/8" bubbler line to drain into tailpiece above the trap.
- STEP 7:** When the fountain operates satisfactorily, install the cover on the box with the louver openings facing down. Attach the bottom plate to the fountain.

IMPORTANT: VALVE BOX MUST BE MOUNTED IN HEATED AREA PROTECTED FROM FREEZING TEMPERATURES. PROVISIONS SHOULD BE MADE TO ALLOW ACCESS TO ACCESS PANEL.

TROUBLESHOOTING

PROBLEM	REPAIR CHECKLIST
1. Bubbler Flow Control.	<ol style="list-style-type: none"> 1. Adjust pressure regulator: <ol style="list-style-type: none"> a. Loosen the locknut. b. Rotate the knob clockwise to increase flow or counterclockwise to reduce flow. c. Tighten the locknut. d. Repeat the above steps until the bubbler flow is correct. e. Replace pressure regulator if necessary.
2. Insufficient bubbler flow	<ol style="list-style-type: none"> 2. <ol style="list-style-type: none"> a. Check that the shut-off valve (not supplied) is wide open. b. Verify minimum 30 psi supply pressure. c. Clean inlet strainer screen located in the valve body. d. Adjust Pressure Regulator (Refer to Step 1).
3. No flow	<ol style="list-style-type: none"> 3. <ol style="list-style-type: none"> a. Check for leaks in the air tubing going from the push button to the valve. b. Make sure the air tubing compression nuts are hand tight. c. Disconnect air tube from push button assembly. Blow into tube to verify valve function. Replace valve if necessary (Model 5881). d. Disconnect air tube from push button. Place finger over air outlet. Push button to test diaphragm. Tighten diaphragm cap screws. Replace diaphragm assembly if necessary (Model VRK2AV).
4. Continued insufficient or varied height of bubbler flow.	<ol style="list-style-type: none"> 4. <ol style="list-style-type: none"> a. Check for kinks in the tubing. b. Replace pressure regulator if necessary.
5. Continuous bubbler flow.	<ol style="list-style-type: none"> 5. <ol style="list-style-type: none"> a. Ensure that push button is not obstructed and springs back to normal position. b. Remove four screws which secure plastic diaphragm block to brass valve body. Pull plastic and rubber diaphragm assembly out of valve body. Locate tiny hole in rubber diaphragm just under lip of plastic part. Clean debris from this hole. Inspect valve seat for grooves. If seat is worn, replace with stainless steel seat (newer models) or replace valve (older models, integral brass seat). c. If valve seat was OK and diaphragm holes were free from debris, inspect rubber button located at center of floating steel disc in valve diaphragm block assembly. If button is worn, turn disk over or replace disk (Model VRK2AV). d. If diaphragm and seats are in good condition, stretch spring slightly. Spring is located behind floating stainless-steel plate. e. Ensure that air bleed port on valve plastic block assembly is not plugged.
6. Water leaking from valve box in wall.	<ol style="list-style-type: none"> 6. <ol style="list-style-type: none"> a. Check tubing connections for leaks. b. The drain-back freeze protection feature drains through a 1" air gap surrounded by plastic funnel (splashguard). If drain is plugged, water will spill out of funnel. Unplug drain.
7. Fountain line from valve box to bubbler blocked with ice.	<ol style="list-style-type: none"> 7. <ol style="list-style-type: none"> a. Check slope of tubing to bubbler, must slope downward from bubbler to drain valve. b. Clean or replace drain-back valve threaded into tee strapped to plastic funnel (Model 6518FRDV).

General Notes: Before tightening nut and ferrule assembly, push tubing into fitting until it bottoms out to ensure correct engagement with O-Ring.

PARTS BREAKDOWN

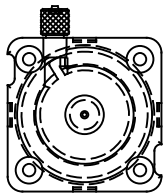
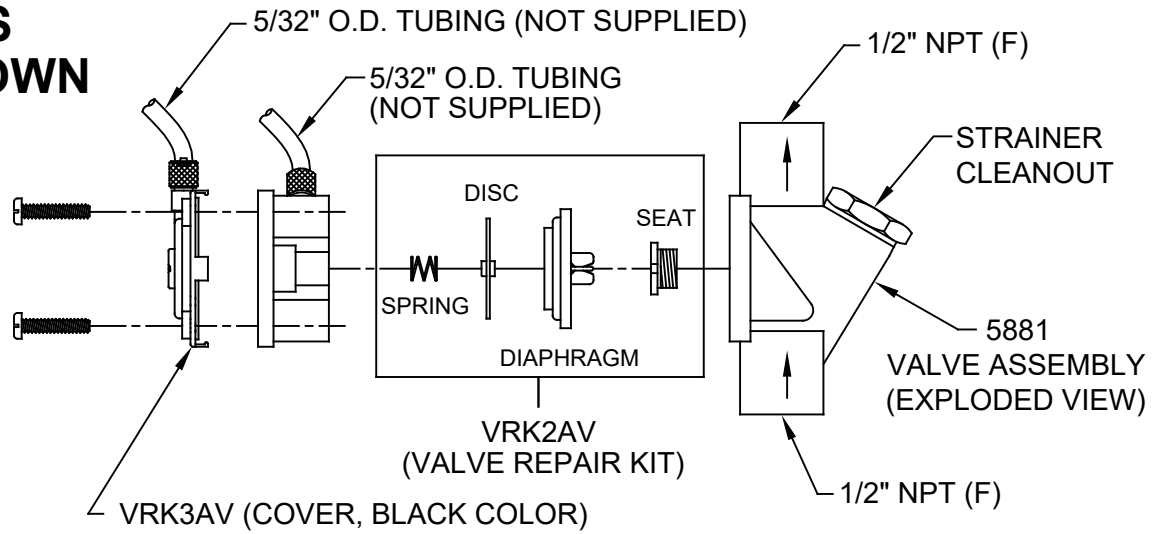

VRK3AV
DETAIL 1

NOTE:
1 THIS BLACK COVER IS NOT INTERCHANGEABLE WITH GRAY COVER USED ON OLDER 5881 VALVES. (SCREWS & WASHERS NOT SUPPLIED WITH COVERS).

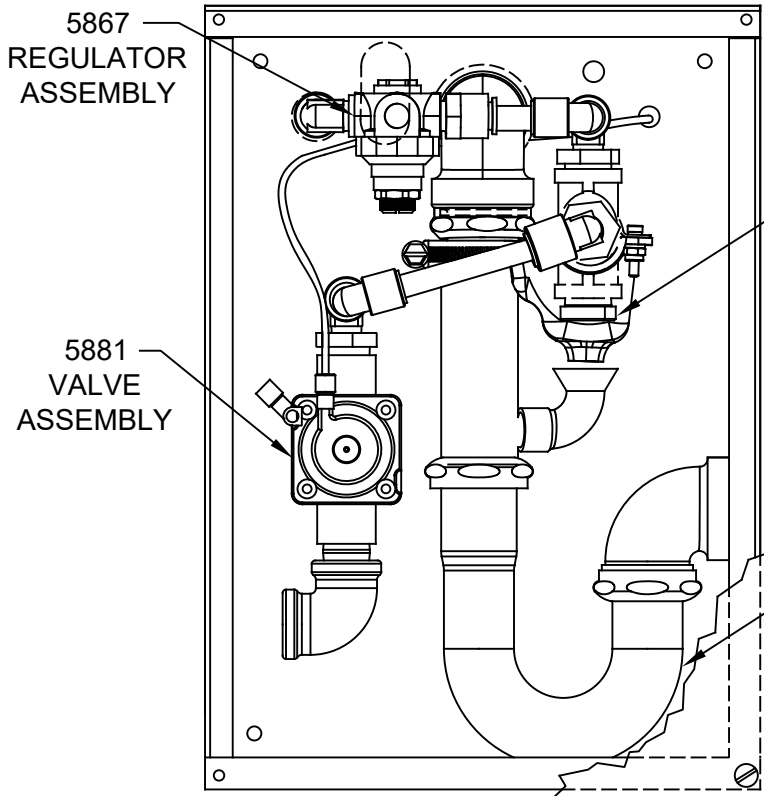

DETAIL B

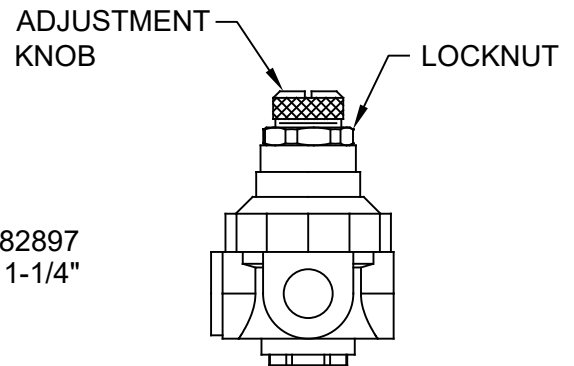

5867 REGULATOR DETAIL

WHEN ORDERING PARTS PLEASE SPECIFY MODEL NUMBER.

		1455 KLEPPE LANE SPARKS, NEVADA 89431 (775) 359-4712 FAX (775) 359-7424 E-MAIL: HAWS@HAWS.CO.COM WEBSITE: WWW.HAWS.CO.COM	
ECN NO.	REVISED PER	BY	MODEL(S)
	ECN: 5799		6521FR
DRAWN	DATE	CHKD	PART NUMBER
F. VASQUEZ	04/13/04	JS	0002077820
APPROVED	DATE		REVISION
FV	07/08/22		18
SCALE: N/A	DRAWING TYPE: PARTS BREAKDOWN	SIZE: A	SHEET 1 OF 1

NOTES:

1. UNIT MAY BE RECESSED MOUNTED IN WALL AS SHOWN IN VIEW "C" OR SURFACE MOUNTED AS SHOWN IN VIEWS "A" AND "B".
2. VALVE MUST BE INSTALLED IN SPACE THAT MAINTAINS A MINIMUM OF 50°F (10°C).
3. DRINKING FOUNTAIN AND BOTTLE FILLER MODELS 1109FR & 1920FR EACH REQUIRE A SEPARATE 6521FR UNIT. DUAL DRINKING FOUNTAIN MODEL 1119FR REQUIRES TWO SEPARATE 6521FR UNITS. THE MODELS LISTED HERE ARE AVAILABLE SEPARATELY OR AS PART OF PRODUCT BUNDLES.

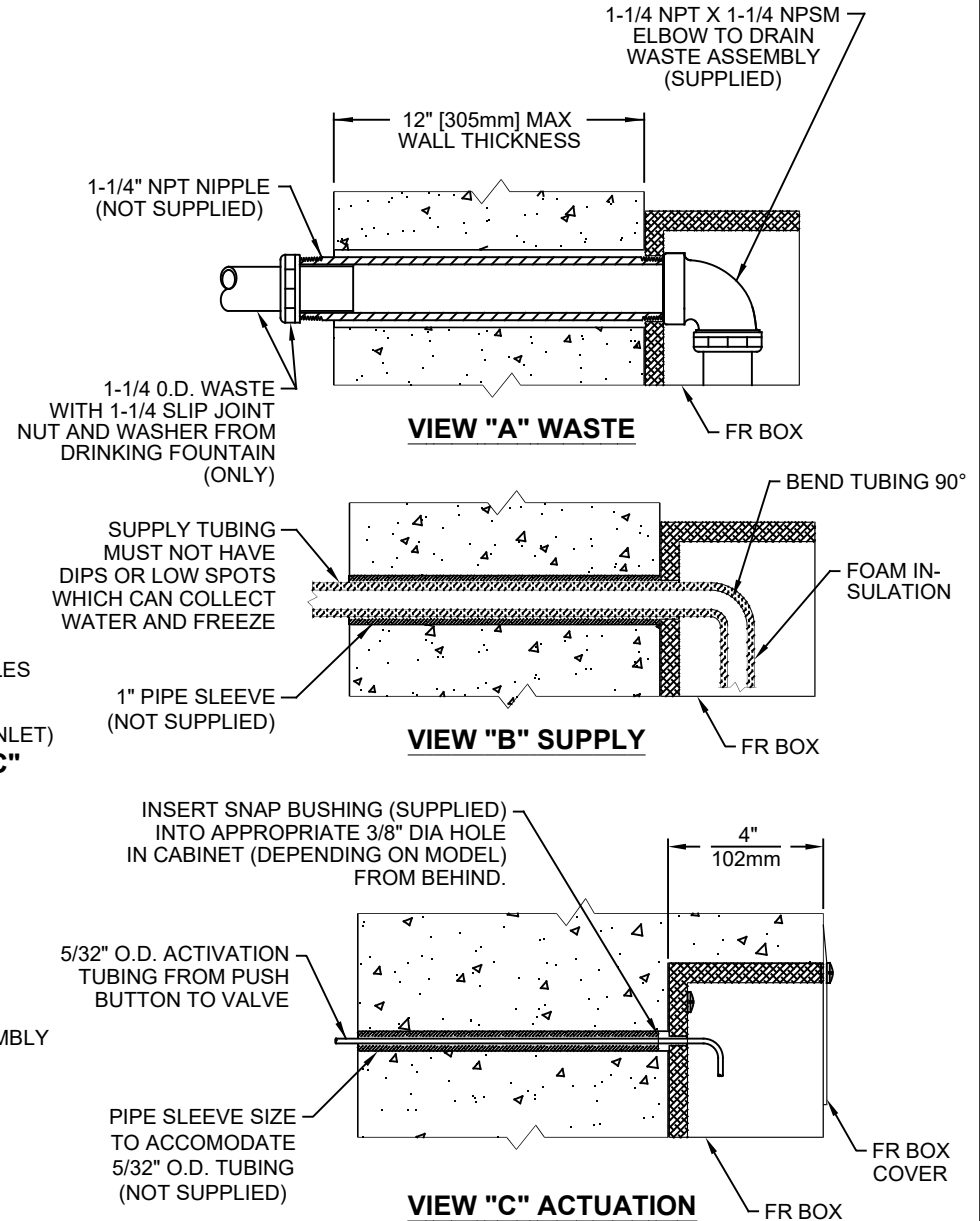
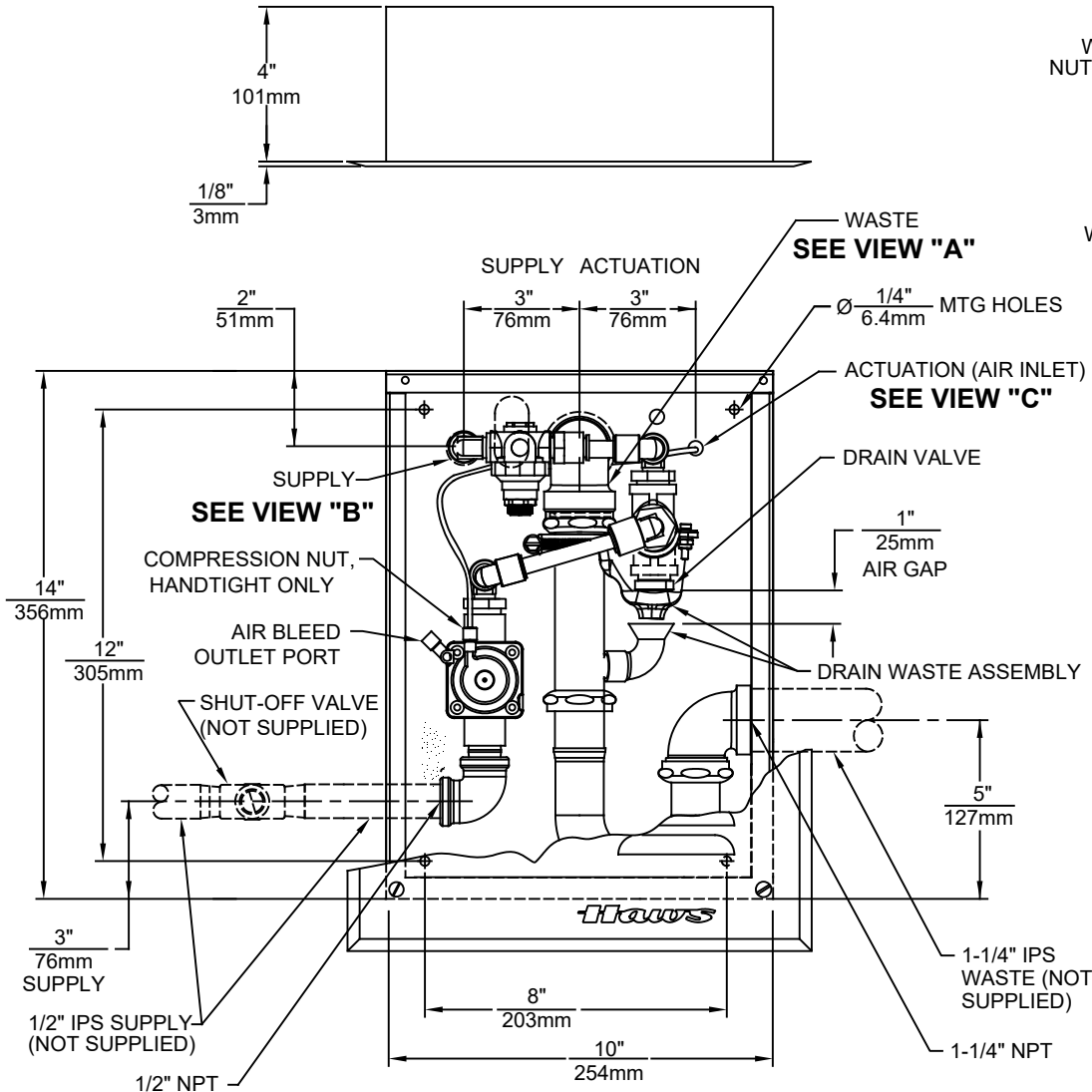



Haws

1455 KLEPPE LANE
 SPARKS, NEVADA 89431
 (775) 359-4712 FAX (755) 359-7424
 E-MAIL: HAWS@HAWSCO.COM
 WEBSITE: WWW.HAWSCO.COM

ECN NO.	REVISED PER	BY	DATE	CHK'D.	MODEL(S)	PART NUMBER
	ECN: 5799	JS	09/92		6521FR	0002077820.D
DRAWN:	CJL	DATE:	09/92	CHK'D.:		DRAWING NO.
APPROVED:	FV	DATE:	07/08/22			09306A00
SCALE: 1:5			DRAWING TYPE: INSTALLATION		SHEET 1 OF 1	