



**INSTALLATION, OPERATION
&
MAINTENANCE INSTRUCTIONS**

1455 Kleppe Lane ♦ Sparks, NV 89431-6467 ♦ (775) 359-4712 ♦ Fax (775) 359-7424
E-mail: haws@hawsco.com ♦ website: www.hawsco.com

No. 0002077325 (13)

**Model 3177FR
Drinking Fountain**

NOTE TO INSTALLER: Please leave this information with the Maintenance Department.

LIMITED WARRANTY

HAWS warrants that this specific product is guaranteed against defective material or poor workmanship for a period of **one year from date of shipment**. HAWS liability under this warranty shall be discharged by furnishing without charge F.O.B. HAWS Factory any goods, or part thereof, which shall appear to the Company upon inspection to be of defective material or not of first class workmanship, provided that claim is made in writing to Haws within a reasonable period after receipt of the product. Where claims for defects are made, the defective part or parts shall be delivered to the Company, prepaid, for inspection. HAWS will not be liable for the cost of repairs, alterations or replacements, or for any expense connected therewith made by the owner or his agents, except upon written authority from HAWS, Sparks, Nevada. HAWS will not be liable for any damages caused by defective materials or poor workmanship, except for replacements, as provided above. Buyer agrees that HAWS shall not be liable for general, special, or consequential damages claimed to arise under the contract of sale. The drinking fountain manufactured by HAWS is warranted to function if installation and maintenance instructions provided are adhered to. The units also must be used for the purpose for which they were intended.

**NO OTHER WARRANTIES EXPRESSED OR IMPLIED ARE AUTHORIZED,
PROVIDED OR GIVEN BY HAWS.**

**SHOULD YOU EXPERIENCE DIFFICULTY WITH THE INSTALLATION OF THIS
MODEL PLEASE CALL:**

TECHNICAL SUPPORT: 1-800-766-5612

FOR CUSTOMER SERVICE: 1-888-640-4297

RECOMMENDED TOOLS: Hack saw, pipe joint sealant, screwdriver, level, 12" adjustable wrench, 10" pipe wrench, 5/64" hex key wrench, 9/16", 1/2", 7/16" socket wrench or open end wrench.

LOCATION OF UNIT: The Model 3177FR Drinking Fountain is a wheelchair accessible drinking water facility. The height dimensions shown, meet current ADA requirements. When installing this unit, local, state or federal codes should be adhered to. If height other than shown is required, then dimensions must be adjusted accordingly.

SUPPLY LINE: The minimum recommended line size is 1/2"IPS. Flowing pressure is 30-90 psi (2-6 ATM) for Model 3177FR. Where sediment or mineral content is a problem, an inlet filter is recommended.

PLUMBING CONNECTIONS: Inlet at freeze valve is 1/2" IPS (male). Waste outlet is 1-1/2" O.D. tailpiece.

MAINTENANCE: Periodically clean the strainer. Refer to 6518FR Operation and Maintenance Sheet for additional information.

TROUBLESHOOTING 3177FR with 6518FR

PROBLEM	REPAIR CHECKLIST
1. Insufficient bubbler flow.	1a. Check that inlet screwdriver stop valve is wide open. (Customer supplied). Turn counterclockwise. b. Verify minimum 30 PSI flowing supply pressure. c. Clean inlet strainer. d. Adjust valve to increase flow. See 6518FR Valve Manual.

General Notes:

Before tightening nut and ferrule assembly, push tubing into fitting until it bottoms out to ensure correct engagement with O-Ring.

For more information about Haws products, see our website: www.hawsc.com

PARTS BREAKDOWN

ITEM	DESCRIPTION	PART NO.
** 1	VALVE, FREEZE RESISTANT	6518FR
2	BOTTOM PLATE	PBM3177
3	STRAINER ASSY	6461
4	BUBBLER HEAD	5703M
5	PUSH BUTTON ASSY	5881PBA
6	ACCESS PLATE	PA3177
7	SPACER	0005365345

** REQUIRED - SOLD SEPARATELY

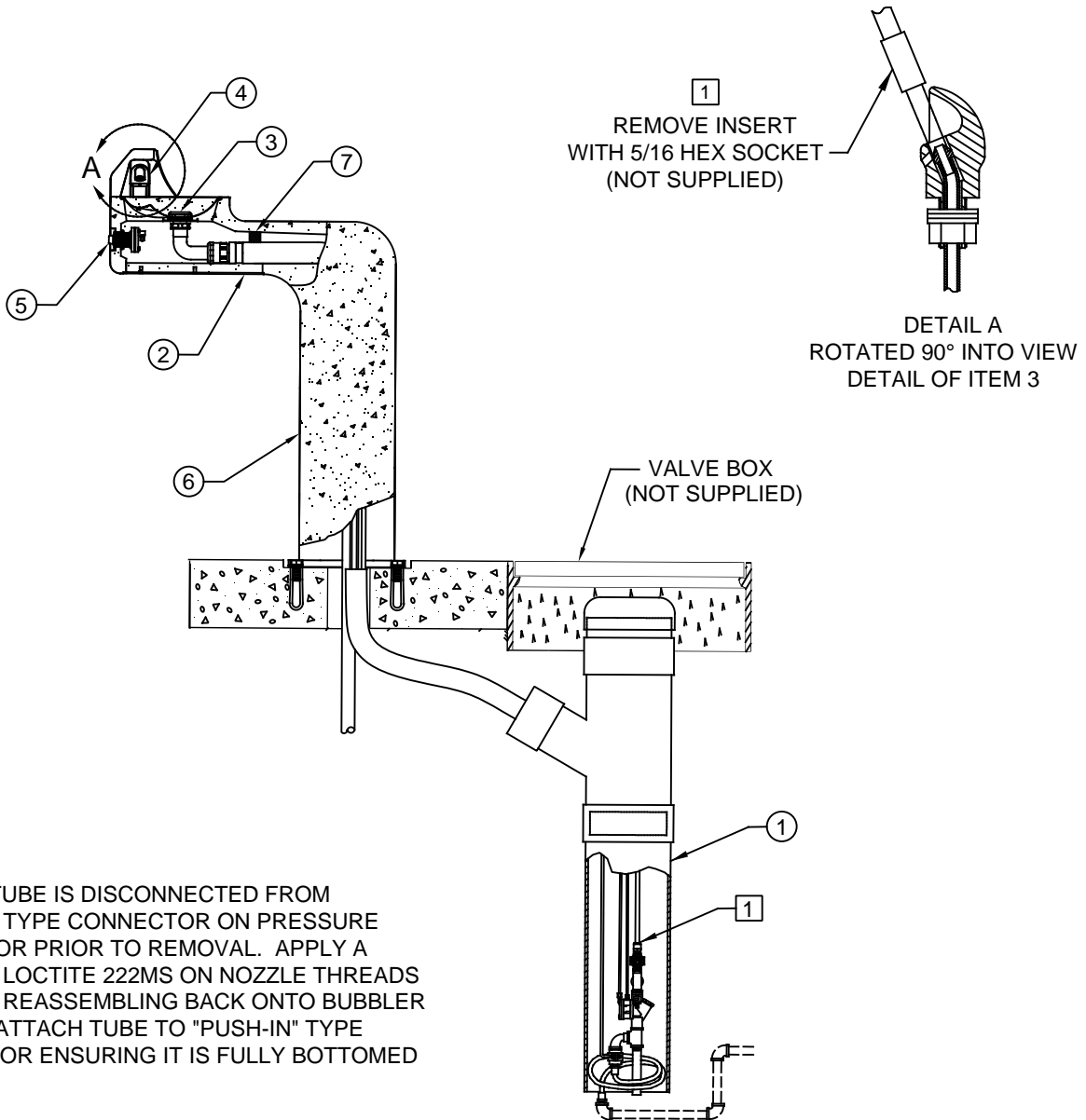

NOTE:

- 1 ENSURE TUBE IS DISCONNECTED FROM "PUSH-IN" TYPE CONNECTOR ON PRESSURE REGULATOR PRIOR TO REMOVAL. APPLY A DROP OF LOCTITE 222MS ON NOZZLE THREADS PRIOR TO REASSEMBLING BACK ONTO BUBBLER HEAD. REATTACH TUBE TO "PUSH-IN" TYPE CONNECTOR ENSURING IT IS FULLY BOTTOMED OUT.

WHEN ORDERING PARTS PLEASE SPECIFY MODEL NUMBER.

		1455 KLEPPE LANE SPARKS, NEVADA 89431 (775) 359-4712 FAX (775) 359-7424 E-MAIL: HAWS@HAWSCO.COM WEBSITE: WWW.HAWSCO.COM	
		ECN NO. REVISED PER BY ECN: 5527 FV	MODEL(S) 3177FR
DRAWN D. OLLOM	DATE 11/25/95	CHKD DP	REVISION 13
APPROVED FV	DATE 04/02/20	SCALE: 1:1	DRAWING TYPE: PARTS BREAKDOWN SIZE: A SHEET 1 OF 1

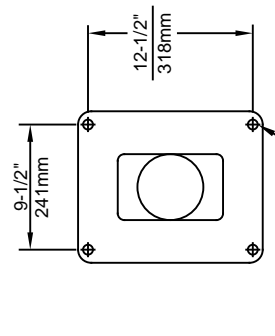
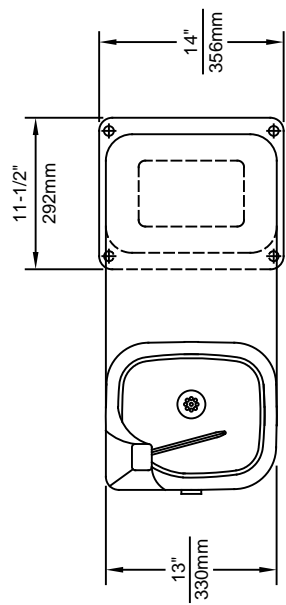

4X 1/2-13 UNC MOUNTING BOLTS (SUPPLIED)

MOUNTING DETAIL

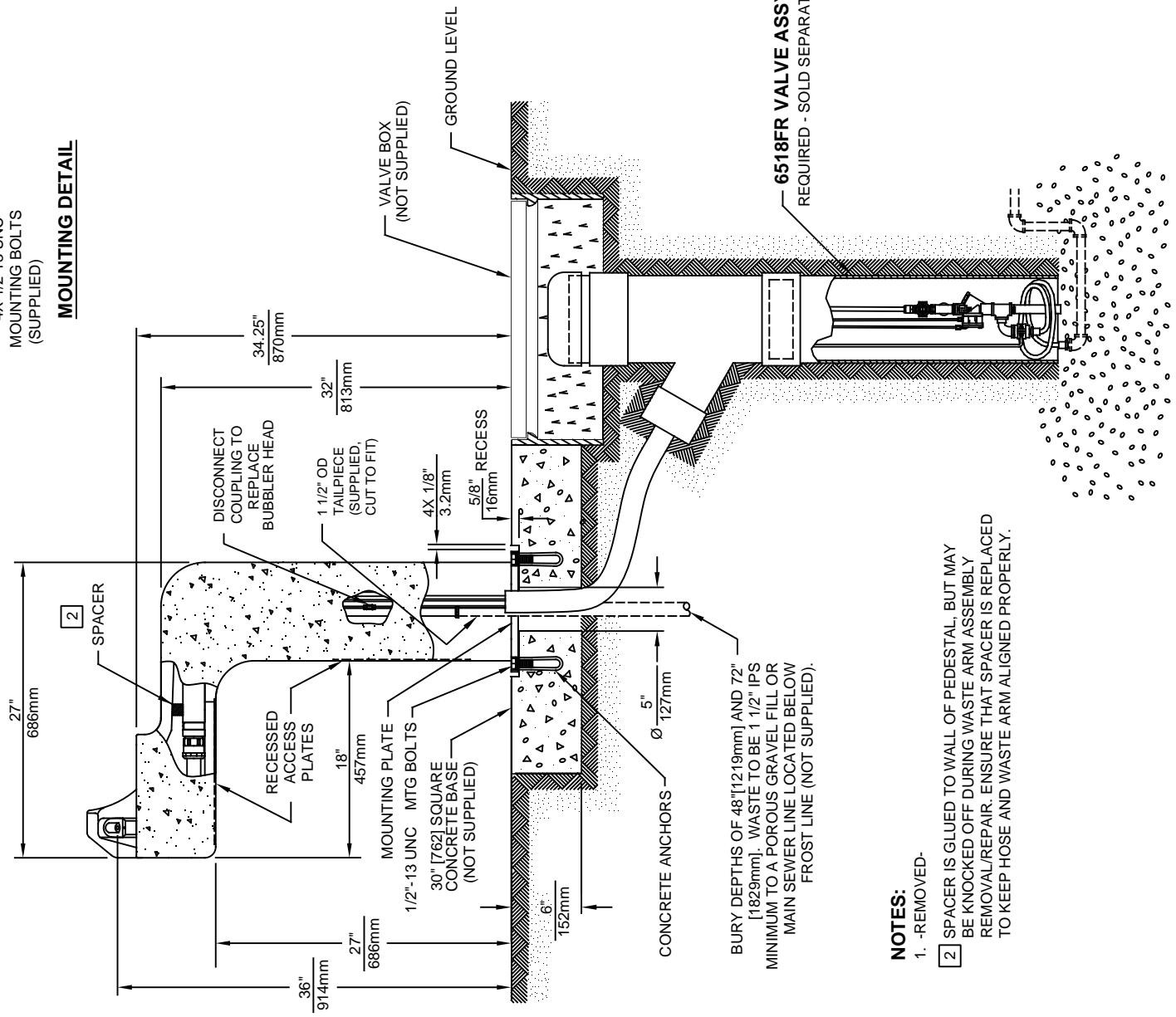

NOTES:

- 1. - REMOVED.
- 2. SPACER IS GLUED TO WALL OF PEDESTAL, BUT MAY BE KNOCKED OFF DURING WASTE ARM ASSEMBLY REMOVAL/REPAIR. ENSURE THAT SPACER IS REPLACED TO KEEP HOSE AND WASTE ARM ALIGNED PROPERLY.

1455 KLEPPE LANE
SPARKS, NEVADA 89431
(775) 359-4712 FAX (775) 359-7424
E-MAIL: HAWS@HAWS.CO.COM
WEBSITE: WWW.HAWS.CO.COM

ECN NO.	REVISED PER	BY:	MODEL(S)		PART NUMBER
	ECN: 5527	FV			0002077325.D
DRAWN:	HM	DATE:	CHKD:		REVISION
		12/01/05	DP		13
APPROVED:		DATE:	SCALE:	DRAWING TYPE:	SIZE:
FV		04/02/20	1:1	INSTALLATION	SHEET 1 OF 1