



INSTALLATION, OPERATION & MAINTENANCE INSTRUCTIONS

1455 Kleppe Lane ♦ Sparks, NV 89431-6467 ♦ (775) 359-4712 ♦ Fax (775) 359-7424
E-mail: haws@hawsco.com ♦ website: www.hawsco.com

No. 2077030 (18)

Model 3060 Drinking Fountain

NOTE TO INSTALLER: Please leave this information with the Maintenance Department.

LIMITED WARRANTY

HAWS warrants that this specific product is guaranteed against defective material or poor workmanship for a period of **one year from date of shipment**. HAWS liability under this warranty shall be discharged by furnishing without charge F.O.B. HAWS Factory any goods, or part thereof, which shall appear to the Company upon inspection to be of defective material or not of first class workmanship, provided that claim is made in writing to Haws within a reasonable period after receipt of the product. Where claims for defects are made, the defective part or parts shall be delivered to the Company, prepaid, for inspection. HAWS will not be liable for the cost of repairs, alterations or replacements, or for any expense connected therewith made by the owner or his agents, except upon written authority from HAWS, Sparks, Nevada. HAWS will not be liable for any damages caused by defective materials or poor workmanship, except for replacements, as provided above. Buyer agrees that HAWS shall not be liable for general, special, or consequential damages claimed to arise under the contract of sale. The drinking fountain manufactured by HAWS is warranted to function if installation and maintenance instructions provided are adhered to. The units also must be used for the purpose for which they were intended.

**NO OTHER WARRANTIES EXPRESSED OR IMPLIED ARE AUTHORIZED,
PROVIDED OR GIVEN BY HAWS.**

**SHOULD YOU EXPERIENCE DIFFICULTY WITH THE INSTALLATION OF THIS
MODEL PLEASE CALL:**

TECHNICAL SUPPORT: 1-800-766-5612

FOR CUSTOMER SERVICE: 1-888-640-4297

RECOMMENDED TOOLS: Hack saw, pipe joint sealant, screwdriver, level, 12" adjustable wrench, 10" pipe wrench, 5/64" hex key wrench, 9/16", 1/2", 7/16" socket wrench or open end wrench.

LOCATION OF UNIT: When installing Model 3060 Drinking Fountain, local, state or federal codes should be adhered to. If height other than shown is required, then dimensions must be adjusted accordingly.

SUPPLY LINE: The minimum recommended line size is 1/2"IPS with 30-90 psi (2-6 ATM) flowing pressure. Where sediment or mineral content is a problem, an inlet filter is recommended.

PLUMBING CONNECTIONS: Inlet is female 1/4" IPS. Waste outlet is 1-1/4" O.D. tailpiece.

MAINTENANCE: Periodically clean the strainer. Refer to 5874 Series Valve Manual for more information.

TROUBLESHOOTING

PROBLEM	REPAIR CHECKLIST
1. Insufficient bubbler flow.	1a. Check that inlet screwdriver stop valve is in wide-open position. b. Verify minimum 30 psi flowing supply pressure. c. Clean strainer. See 5874 Series Valve Manual. d. Adjust valve to increase flow. Use front adjust screw or see 5874 Series Valve Manual.

General Notes:

Before tightening nut and ferrule assembly, push tubing into fitting until it bottoms out to ensure correct engagement with O-Ring.

For more information about Haws products, see our website: www.hawsc.com

ITEM	DESCRIPTION	PART NO.
1	STRAINER WASTE ASSY, PCP	6461
2	BUBBLER HEAD ASSY, PCP	5701SL
3	BUTTON, PUSH, NON-FLANGED, PCP	5874PB
4	VALVE REPAIR KIT	VRK5874
5	PUSH BUTTON ASSY	PBA7
6	VALVE, BIB FAUCET, PCP	6250LF
7	PLATE, ACCESS, 3060, W/ HOLE	0004499489

* DENOTES OPTIONAL PART.

NOTES:

- 1 5874PB (ITEM 3) INCLUDES VRK5874 CARTRIDGE ASSEMBLY (ITEM 4) AND PBA7 RECESSED PUSH BUTTON (ITEM 5).
- 2 USE MODEL 6250LF WITH ACCESS PLATE, PN 0004499469.
- 3 ENSURE TUBE IS DISCONNECTED FROM PUSH BUTTON VALVE BODY PRIOR TO REMOVAL. APPLY ONE DROP OF LOCTITE 222MS TO NOZZLE THREADS PRIOR TO FASTENING BACK ONTO BUBBLER HEAD. RE-ATTACH TUBE TO VALVE.

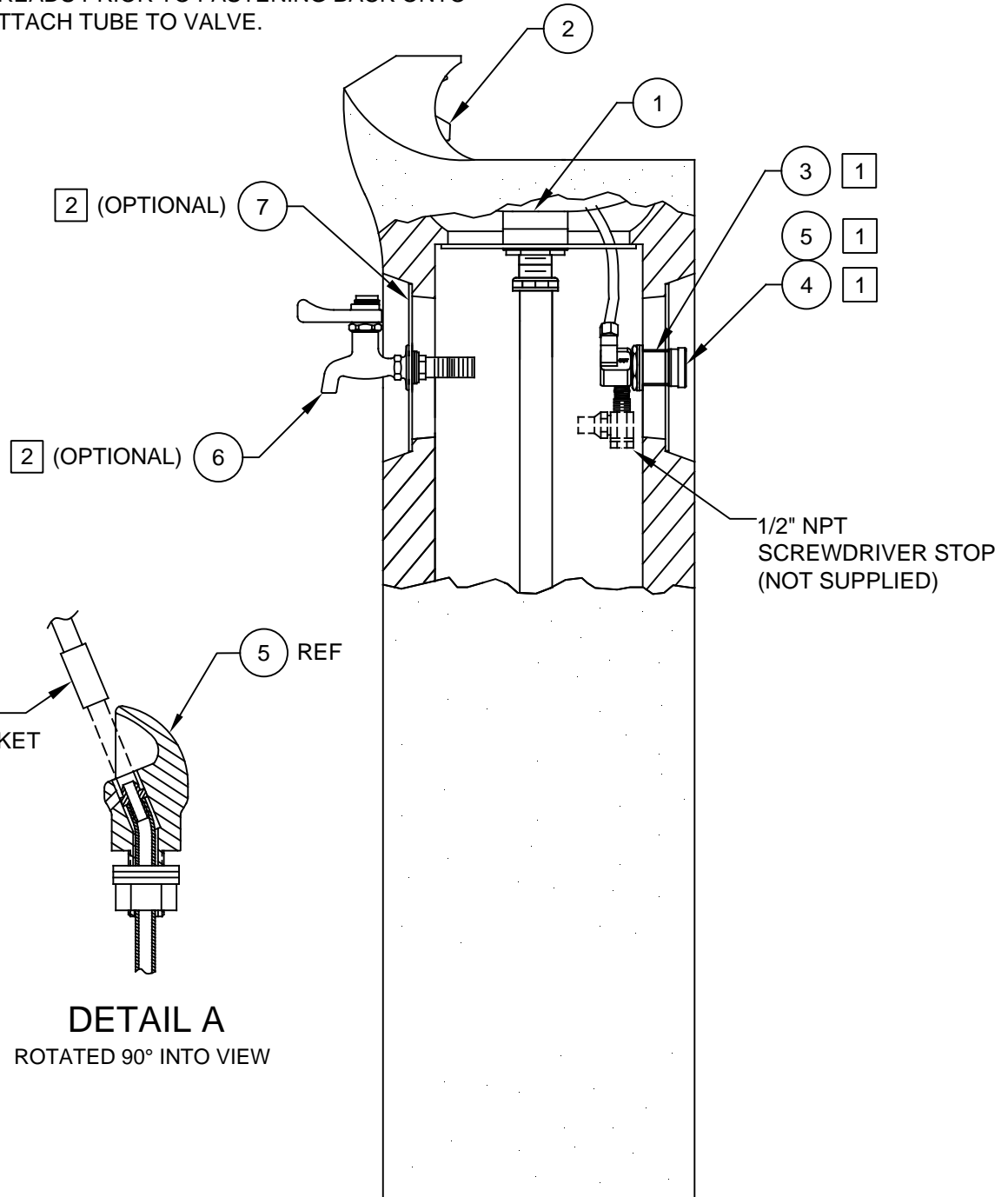

PARTS BREAKDOWN



Haws

1455 KLEPPE LANE
 SPARKS, NEVADA 89431
 (775) 359-4712 FAX (775) 359-7424
 E-MAIL: HAWS@HAWSCO.COM
 WEBSITE: WWW.HAWSCO.COM

ECN NO.	REVISED PER	BY	MODEL(S)	PART NUMBER
	ECN: 5286	JP	3060	0002077030
DRAWN	DATE	CHKD		REVISION
D> OLLOM	11/25/95	VWC		18
APPROVED	DATE			
FV	03/07/18			

WHEN ORDERING PARTS PLEASE SPECIFY MODEL NUMBER.

THIS DOCUMENT IS TRUE AND CORRECT AT TIME OF PUBLICATION. CONTINUED PRODUCT IMPROVEMENTS MAKE SPECIFICATIONS AND MEASUREMENTS SUBJECT TO CHANGE WITHOUT NOTICE.

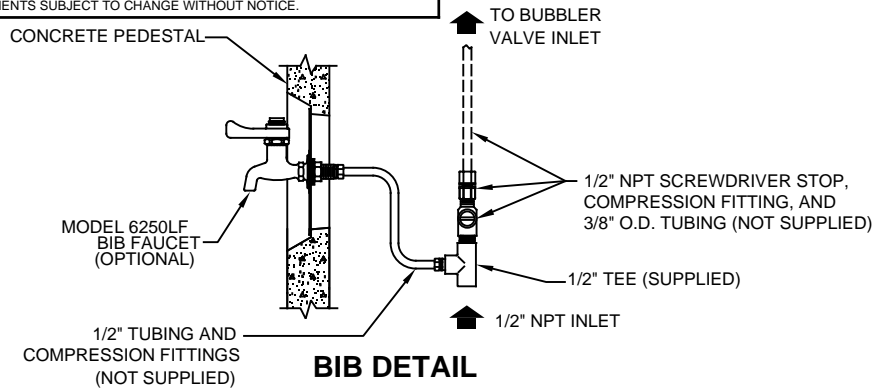

BIB DETAIL

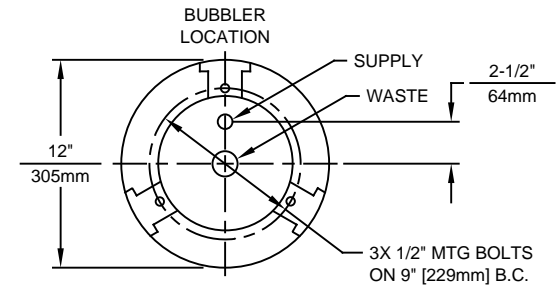

MOUNTING DETAIL

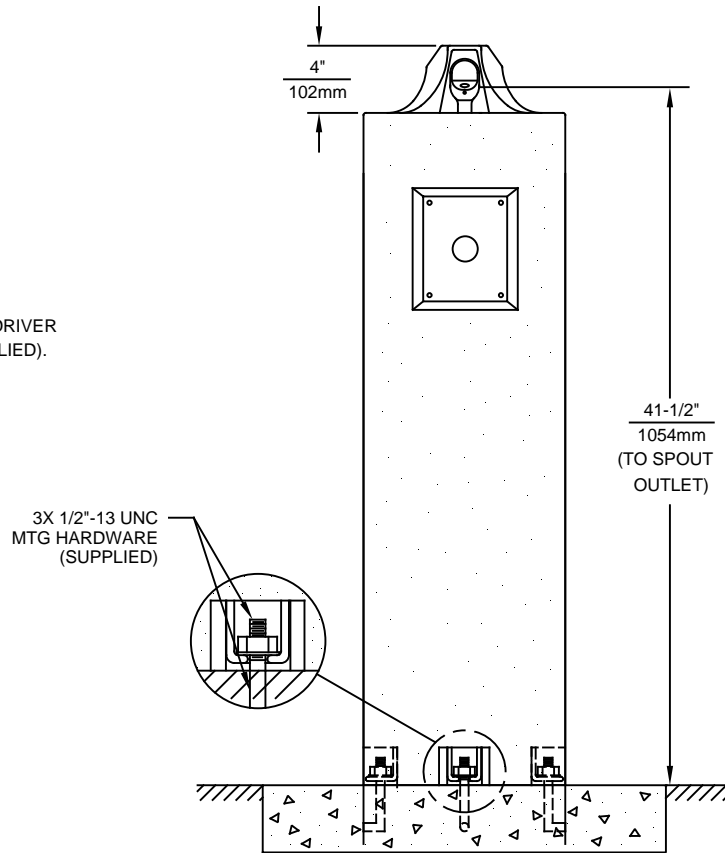
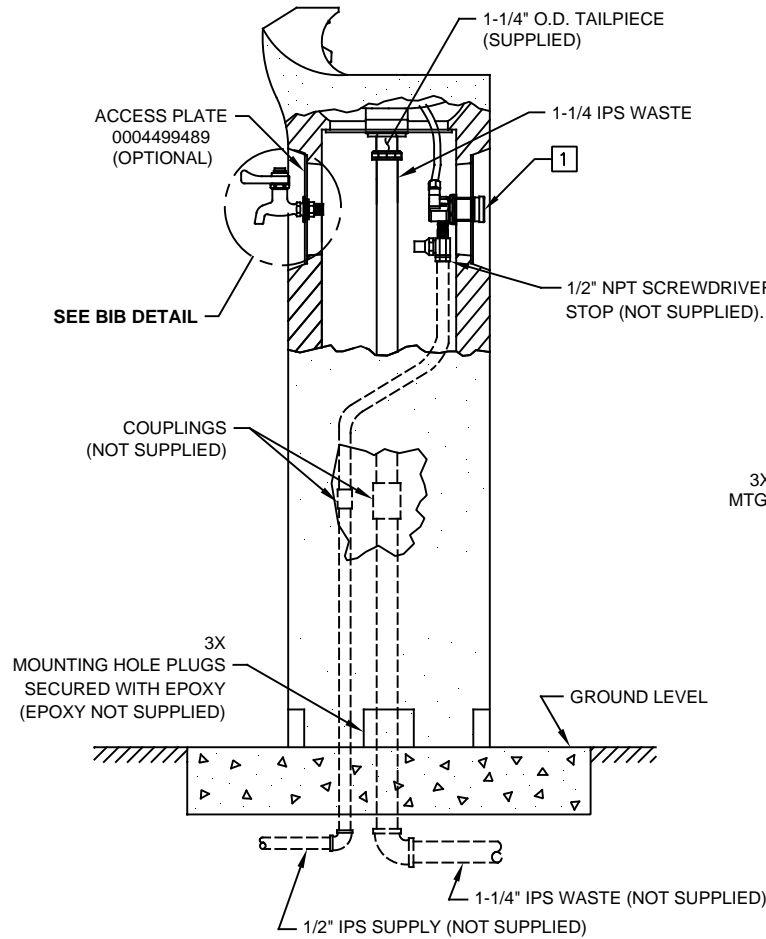

NOTES:

1 REFER TO 5874 SERIES OPERATION AND MAINTENANCE MANUAL FOR PUSH BUTTON AND VALVE INSTALLATION/MAINTENANCE INSTRUCTIONS.

		Haws [®]		1455 KLEPPE LANE SPARKS, NEVADA 89431 (775) 359-4712 FAX (775) 359-7424 E-MAIL: HAWS@HAWSCO.COM WEBSITE: WWW.HAWSCO.COM	
ECN NO.	REVISED PER	BY:	MODEL(S)	PART NUMBER	
D-5	11/25/95	OLLOM	3060	0002077030.D	
APPROVED:	DATE:	CHKD.:	SCALE:	DRAWING TYPE:	REVISION
FV	03/07/18	VWC	12:1	INSTALLATION	18
				SIZE:	SHEET 1 OF 1
				A	