



Haws[®]
Since 1906

OWNER'S MANUAL

1455 Kleppe Lane ♦ Sparks, NV 89431-6467 ♦ (888) 909-4297

♦ website: www.hawesco.com

No. 0510000665 (5)

Model 2000S Bottle Filler with Lifecycle Control

LIMITED WARRANTY

HAWS warrants that all of its products are guaranteed against defective material or poor workmanship for a period of **three years from the date of shipment**. The foregoing notwithstanding, *HAWS* warrants certain specific products or components thereof for an adjusted period. A list of these excepted products and components and a description of their respective warranty terms may be found here: www.hawesco.com/warranty. *HAWS'* liability under this warranty shall be discharged by furnishing without charge F.O.B. *HAWS* factory any goods, or part thereof, which shall appear to the Company upon inspection to be of defective material or not of first-class workmanship, provided that a claim is made in writing to Company within a reasonable period after receipt of the product. Where claims for defects are made, the defective part or parts shall be delivered to the Company, prepaid, for inspection. *HAWS* shall not be liable for the cost of repairs, alterations or replacements, or the labor required to implement them, or for any expense connected therewith made by the owner or owner's agents, except upon written authority from *HAWS*. *HAWS* shall not be liable for any damages caused by defective materials or poor workmanship, except for replacements, as provided above. Buyer agrees that *HAWS* has made no other warranties either express or implied in addition to those above stated, except that of title with respect to any of the products or equipment sold hereunder and that *HAWS* shall not be liable for general, special, incidental, or consequential damages claimed to arise under the contract of sale.

Equipment manufactured by *HAWS* is warranted to function if installation and maintenance instructions provided are adhered to. The units also must be used for the purpose for which they were intended. Any *HAWS* emergency equipment is intended to supplement first-aid treatment. Due to widely varying conditions, *HAWS* cannot guarantee that the use of this emergency equipment will prevent serious injury or the aggravation of existing or prior injuries.

EXCEPT AS EXPRESSLY STATED HEREIN, HAWS HEREBY DISCLAIMS ALL WARRANTIES, WHETHER EXPRESS OR IMPLIED, ARISING BY LAW OR OTHERWISE, INCLUDING WITHOUT LIMITATION, ANY IMPLIED WARRANTIES OF MERCHANTABILITY AND FITNESS FOR A PARTICULAR PURPOSE. THIS WARRANTY MAY NOT BE MODIFIED OR EXTENDED WITHOUT THE WRITTEN CONSENT OF HAWS. REMEDIES AND REPLACEMENTS STATED HEREIN ARE EXCLUSIVE. IN NO EVENT SHALL HAWS BE LIABLE FOR ANY SPECIAL, PUNITIVE, CONSEQUENTIAL OR INCIDENTAL DAMAGES TO ANY PERSON INCLUDING BUT NOT LIMITED TO DAMAGES FOR LOSS OF USE OR PROFITS, SUBSTITUTE PRODUCTS OR COSTS, PROPERTY DAMAGE, OR OTHER MONETARY LOSS.

SHOULD YOU EXPERIENCE DIFFICULTY WITH THE USE OF THIS MODEL, OR REQUIRE REPLACEMENT PARTS, PLEASE CALL:

**TECHNICAL SUPPORT:
1-800-766-5612**

HOURS OF OPERATION: MON-THURS 7:00a.m. - 4:30p.m. PT. FRI 7:00a.m. - 11:00a.m. PT

QUICK START REFERENCE (SEE INSTALLATION INSTRUCTIONS FOR FURTHER DETAILS)

RATED SERVICE FLOW: 0.5 GPM (2725L/day)

OPERATING PRESSURE: 30-90 PSI

OPERATING TEMPERATURE: 35-100°F (1.7-37.8°C)

FILTER CAPACITY: 2500 gallons (9460L) or 1 year

REPLACEMENT FILTER CARTRIDGE: Electronic Lifecycle Control Filter Model 6423

WATER SUPPLY REQUIREMENTS: 30-90 PSI (2-6 ATM) supply; cold water only.

Do not use with water that is microbiologically unsafe or of unknown quality without adequate disinfection before or after the system. Systems certified for cyst reduction may be used on disinfected waters that may contain filterable cysts.

WASTE REQUIREMENTS: An acceptable trap must be used after the waste bend.

NOTE: When installing this unit, all pertinent local, state, or federal codes should be adhered to.

Maintenance Label

- When installation of the bottle filler is complete, **obtain a phone number for the sales representative that sold you the unit.** Write this number into the maintenance label located in the lower right-hand corner of the front of the unit (see below) and use for maintenance and troubleshooting questions.
- If any issues or questions arise that cannot be addressed by this Owner's Manual, refer to this label, which also contains the Haws® (888) 909-4297 customer service phone number and a serial number for tracking.

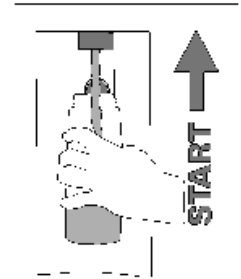
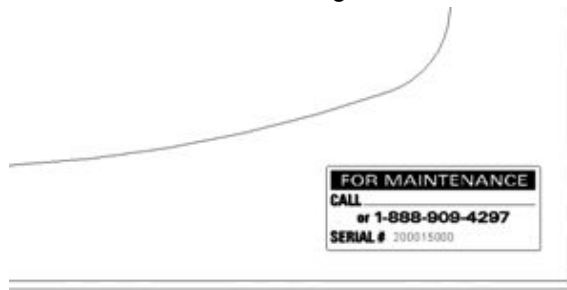

General Operation

- Approach the bottle filler with a bottle (or other multi-use water container). Note the start/stop activation label (seen to right) at the center of the unit – in & up to activate; down & out to deactivate.
- Place the bottle in the opening and move upward to the sensor (see below).
- When the sensor detects the bottle, a blue light will activate to help position the bottle under the nozzle. After a slight delay, water will dispense.
- When the bottle is filled, lower it from the sensor to stop the water flow.
 - There is a 30 second shut-off feature to prevent needless dispensing.

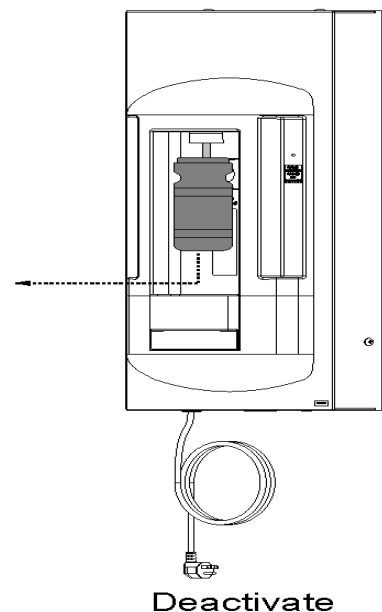
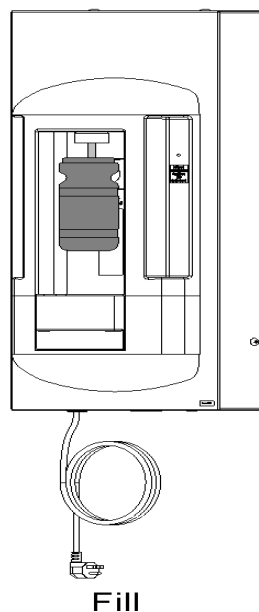
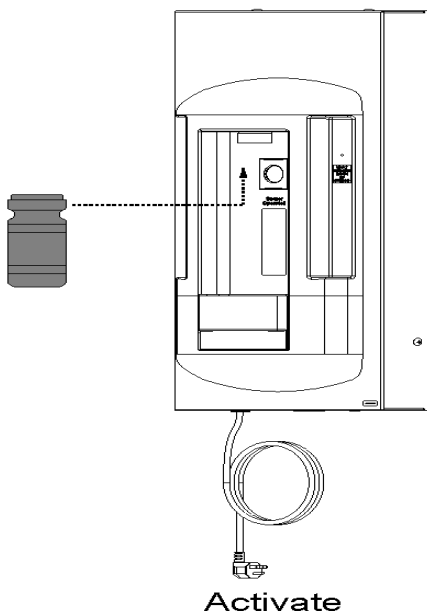
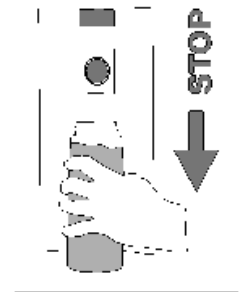

General Operation (continued)

- As water dispenses, the LED light to the far right of the sensor (see right) will flash **green** several times, indicating that the filter is working properly. This same LED will change to a blinking **yellow** when filter life reaches 10% remaining (filter change recommended).
- When the filter has reached end of life, the indicator LED will flash **red** and the unit **will not dispense** water until the filter is replaced.

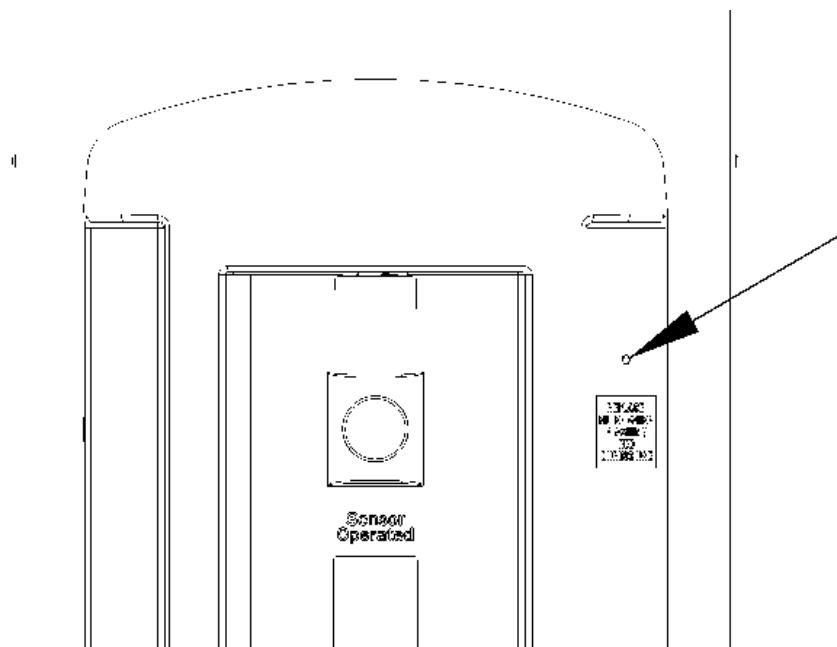

Auto Purge & Periods of Inactivity

- The bottle filler is designed to purge itself after every 24 hours of non-use. This effectively removes the standing water from the system and introduces new water in an effort to prevent the growth of bacteria.
- If there is an atypically lengthy period of time during which the bottle filler is not in use, it is advisable that the filter cartridge be replaced when the system comes back on line.

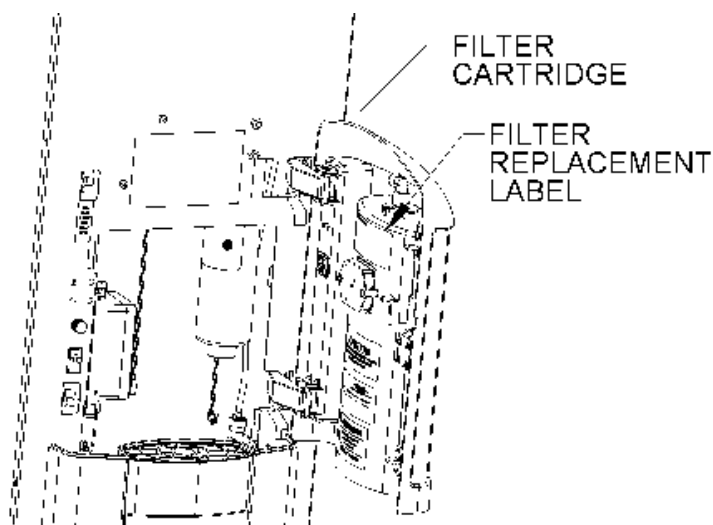

Water Quality

- The bottle filler is not intended to purify water. Do not use this system with water that is microbiologically unsafe or of unknown quality without adequate disinfection before or after the system. Individuals requiring water of special microbiological purity should follow the advice of their doctor or local health officials regarding the use and consumption of their tap water.

Maintenance

WARNING:

1. Make certain power is disconnected before servicing to reduce the risk of electrical shock.
2. Do not touch any circuit board for any reason.

CAUTION: Do not use an abrasive cloth, brush, polishing compound, or abrasive cleaner to clean any part of the unit.

Filter Replacement

- For filter replacements, please contact Haws customer service at 1-888-909-4297, or visit www.Hawesco.com. It is recommended that at least one filter replacement is on hand for immediate replacement purposes.
- Maintenance personnel can determine filter life as outlined on page 4. The filter should be changed if the filter LED begins to blink yellow or red, if 1 year has elapsed since the filter was installed, or if the water output begins to decrease.
- **To open the unit**, slide the supplied hex key (or a long, small slotted screwdriver) into the notch in the left-hand side of the hinged upper panel and press the key firmly in that same direction. This will disengage the internal spring latch. Simultaneously pull open the hinged panel. Take care not to damage the stainless steel panel or the spring latch in this process.
 - NOTE: Opening the hinged panel cuts the power to the sensor and the solenoid valve, preventing accidental activation.

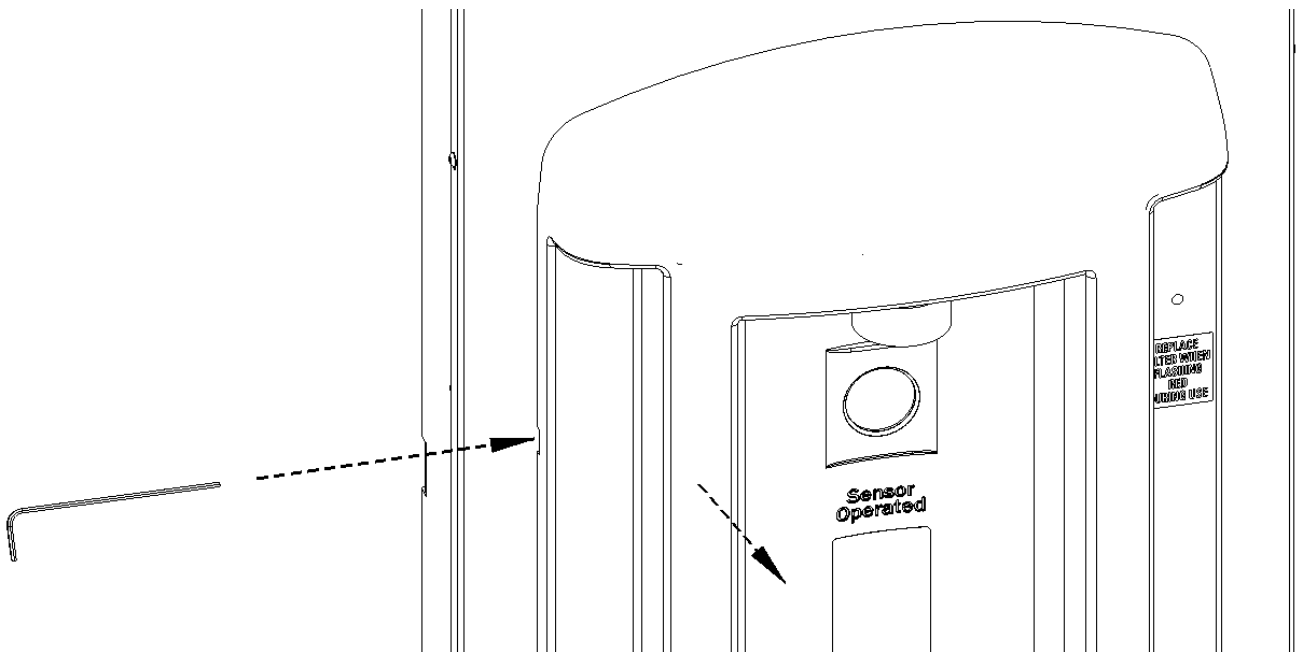

Maintenance (continued)

- An instructional label is visible when the hinged panel is opened, noting how to replace the filter (see below).
 - NOTE: Water does not need to be shut off to replace the filter cartridge; however, it should be shut off if the filter head is going to be left without a cartridge installed for a long period of time.

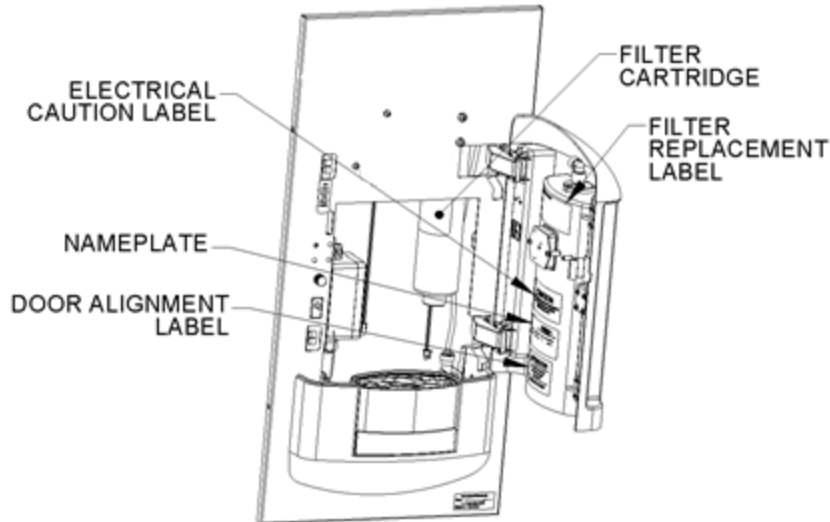

1. Disconnect the old filter cartridge's wiring and unscrew the old cartridge.
2. Screw the new cartridge firmly into the filter head and connect the new cartridge's wiring.
3. The filter status LED should flash green both after the hinged plastic panel is first closed and when water is dispensing. If it does not, consult the Troubleshooting Guide.
4. **Approximately five gallons** of water must be run through the system after the cartridge is installed in order to remove the loose carbon particles from the filter cartridge and any air bubbles from the system.
5. Open the unit and examine to assure that there are no leaks; close unit.

Purge Cycle & Cleanliness

- For hygienic purposes, the unit purges itself briefly if it has not been used in 24 hours. However, it is recommended that the drain basin be regularly cleaned and disinfected with bleach – use $\frac{3}{4}$ cup bleach and mix in 1 gallon of water. Pour slowly throughout the drain basin and let stand for 5 minutes. Flush with water and let air dry.
 - To access the drain basin for cleaning, open the hinged upper panel and remove the drain grate (see right).
- The rest of the unit may be cleaned with a mild sanitizing cleaner.

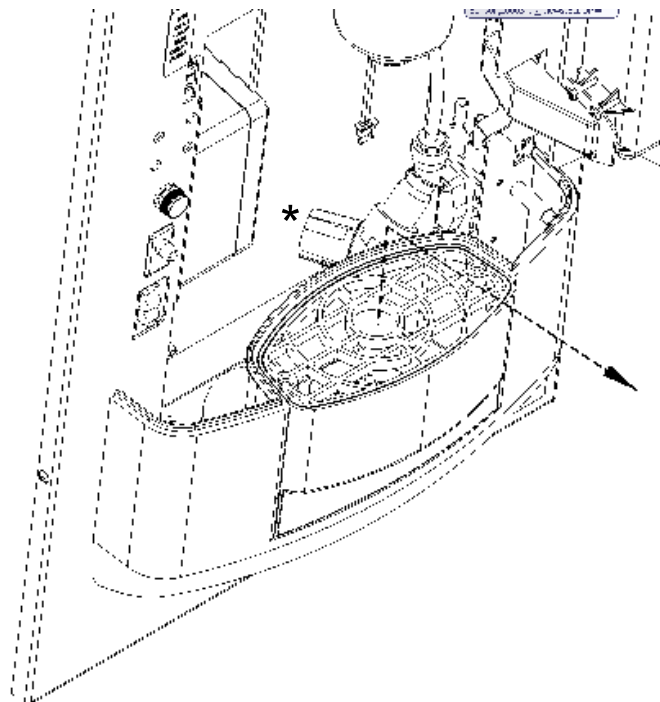

BOTTLE FILLER TROUBLESHOOTING

PROBLEM	REPAIR CHECKLIST
1. Low water flow.	<ul style="list-style-type: none"> a. Change filter cartridge. b. Verify minimum 30 psi supply pressure. c. Check that the inlet screwdriver stop valve (not supplied) is in the wide-open position. d. Check that pressure regulator is open (in picture at bottom of page 6; marked with asterisk – pull knob out and rotate counterclockwise from front of unit). e. Contact Haws Technical Support @ 1-800-766-5612.
2. Unit activates by itself.	<ul style="list-style-type: none"> a. Unit self-purges every 24 hours if not used. b. Check the filling area for (and remove) any debris, etc. c. Contact Haws Technical Support @ 1-800-766-5612.
3. Water will not flow; blue nozzle LEDs activate.	<ul style="list-style-type: none"> a. If the filter indicator LED is blinking red, either the filter has expired and must be replaced, or its wiring is not connected. b. If a new filter was just installed, cycle power off and on (e.g. open/close hinged panel). c. If the nozzle LEDs have activated by themselves, the sensor is detecting something and has timed out. Check the filling area for (and remove) any debris, etc. d. Verify inlet water pressure; check that any inlet screwdriver stop valve is wide open. e. Trigger the sensor and listen for a click or a hum to indicate that the solenoid is functioning. If nothing is heard, the solenoid may be malfunctioning. f. Contact Haws Technical Support @ 1-800-766-5612.
4. Water will not flow; blue nozzle LEDs do not activate.	<ul style="list-style-type: none"> a. Keep your hand closer to the top of the bottle, etc. while attempting to fill it. b. Make sure the unit has power (look up at the nozzle – the LEDs should be flashing). c. Check to see if fuse has blown (fuse holder is located on stainless panel behind hinged plastic panel). Replace only with Bussmann MDL-1/4" 0.25A time-delay fuses. d. Check the circuit breaker for this unit. e. Contact Haws Technical Support @ 1-800-766-5612.
5. Water is observed anywhere other than the outlet nozzle.	<ul style="list-style-type: none"> a. Shut off water supply and contact Haws Technical Support @ 1-800-766-5612.
6. Water excessively splatters in drain.	<ul style="list-style-type: none"> a. Turn down the pressure regulator (in picture at bottom of page 6; marked with asterisk – pull the knob out and rotate it clockwise from the front of the unit). b. Check nozzle for debris (if necessary, the nozzle may be unbolted from the inside by removing the 2 Phillips screws).
7. Filter status LED is blinking yellow or red when unit is used.	<ul style="list-style-type: none"> a. Replace filter cartridge; ensure wiring is connected properly. b. If a new filter was just installed, cycle power off and on (e.g. open/close hinged panel).