



Haws®

model 1501-1920W

ADA Vandal-Resistant Enameled Iron Fountain and Bottle Filler

FEATURES & BENEFITS

CONSTRUCTION

Heavy-duty ADA accessible cast iron bowls with a glossy white enamel finish are designed for the toughest of applications, and at the same time is gentle to all users with its soft rounded corners. Unit also ships with vandal-resistant bottom plates to provide added peace of mind.

BOTTLE FILLER

Vandal-resistant, powder-coated white 14-gauge Type 304 stainless steel bottle filler housing with push button operation and 1 gpm (3.78 L) laminar flow.

FOUNTAIN VALVES

The push-button activated valves have all stainless steel bodies, with chrome plated brass push button assemblies which allow for front access to water stream adjustment, water control cartridge, and water supply strainer replacement without having to go through the bottom plate. Operating pressure range of 30 to 90 psi (2.1 to 6.2 bar).

BUBBLER HEADS

Polished chrome-plated brass bubbler head with Integral laminar flow prevents splashing while providing a superior flow pattern. The integral 11/16" dia. basin shank and stainless anti-rotation roll pin for vandal resistance strength. Shielded, angled stream opening provides a steady, sanitary source of drinking water at .45 gpm.

MOUNTING

3/16" (.47 cm) thick steel mounting plate is larger, thicker and stronger than any other plate in the industry, and shall include the all-thread studs, nuts, and washers which allows for easy installation to a framed wall.

VANDAL-RESISTANT

The bubbler heads, push buttons, drain strainers and bottom plates are locked in place, discouraging unwanted vandal tampering.

OPTIONS

Mounting Plate: Model 6700, in-wall mounting plate for model 1920W.

Mounting Plate: Model 6700R, on-wall mounting plate for model 1920W.

Support Frame: Model 6800 In-wall floor mounted fixture support legs, welded steel 4-bolt floor flanges, and supplied with 'U' bolts and hardware.

Remote Drinking Fountain Water Chiller: Model HCR8, 8 gph (30.3 L) remote water chiller provides instantaneous cooling to meet a continuous demand for chilled water.



REQUIRED MODELS

1501 / 6715 / 1920W / BP32W

Order these items to make up the Model 1501-1920W white enameled-iron fountain with white painted stainless steel back panel, bottle filler with white painted stainless steel back plate, and fountain mounting plate shown above.

SPECIFICATIONS

Model 1501-1920W wall mounted vandal-resistant ADA dual drinking fountain and bottle filler shall include white enameled-iron basins with 14 gauge Type 304 powder-coated Stainless Steel bottle filler bracket, 100% lead-free waterways, vandal-resistant push-button operated stainless steel valves with front-accessible cartridge and flow adjustment, polished chrome-plated brass vandal-resistant bubbler heads with integral anti-squirt flow, 1 gpm (3.78 L) laminar flow bottle filler, chrome plated brass vandal-resistant waste strainer, vandal-resistant bottom plates, and a 1-1/4" NPT trap. Manufactured to be lead-free by all known definitions including NSF/ ANSI/CAN 61-Section 9, NSF/ANSI/CAN 372, California Proposition 65, and the Federal Safe Drinking Water Act. Product is compliant to California Health and Safety Code 116875 (AB 1953-2006), and NSF/ ANSI/ CAN 61: Q ≤ 1.



NOTES:

- 1 1 1/4" DIM TO SLOTTED OPENING ON THE MOUNTING PLATE MUST BE ON THE TOP LEFT HAND SIDE WHEN INSTALLED.
- 2 1/2" DIM TO SLOTTED OPENING ON THE BACKPANEL MUST BE ON TOP LEFT HAND SIDE WHEN INSTALLED.
- 3 HOLD ROUGH-IN DIMENSIONS ± 1/4" (6.4MM).
4. WHEN INSTALLING THIS UNIT, LOCAL, STATE, OR FEDERAL CODES SHOULD BE ADHERED TO. FOR INSTALLATION HEIGHTS OTHER THAN SHOWN, DIMENSIONS MARKED (?) MUST BE ADJUSTED ACCORDINGLY.
- 5 REFER TO 5874 SERIES OPERATION AND MAINTENANCE MANUAL FOR PUSH BUTTON AND VALVE INSTALLATION/MAINTENANCE INSTRUCTIONS.

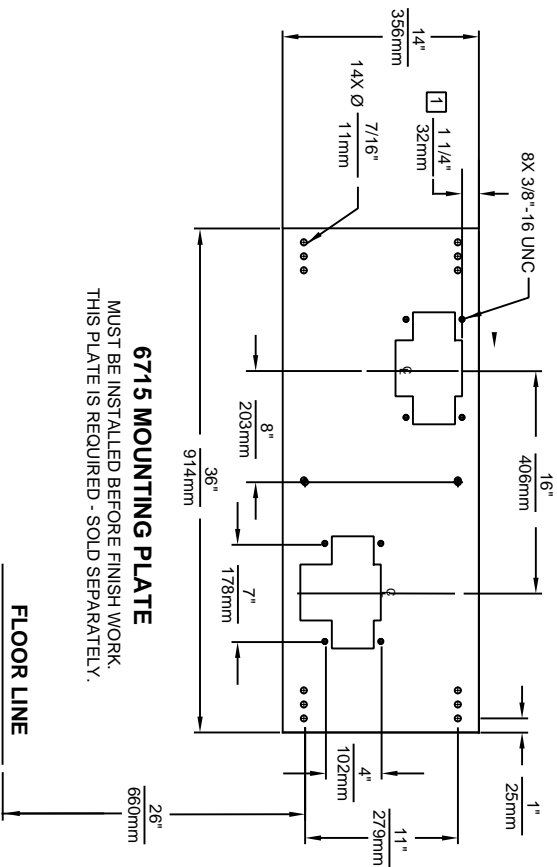

6715 MOUNTING PLATE
 MUST BE INSTALLED BEFORE FINISH WORK.
 THIS PLATE IS REQUIRED - SOLD SEPARATELY.

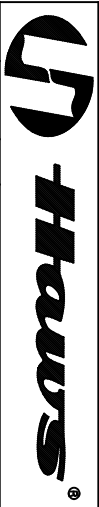
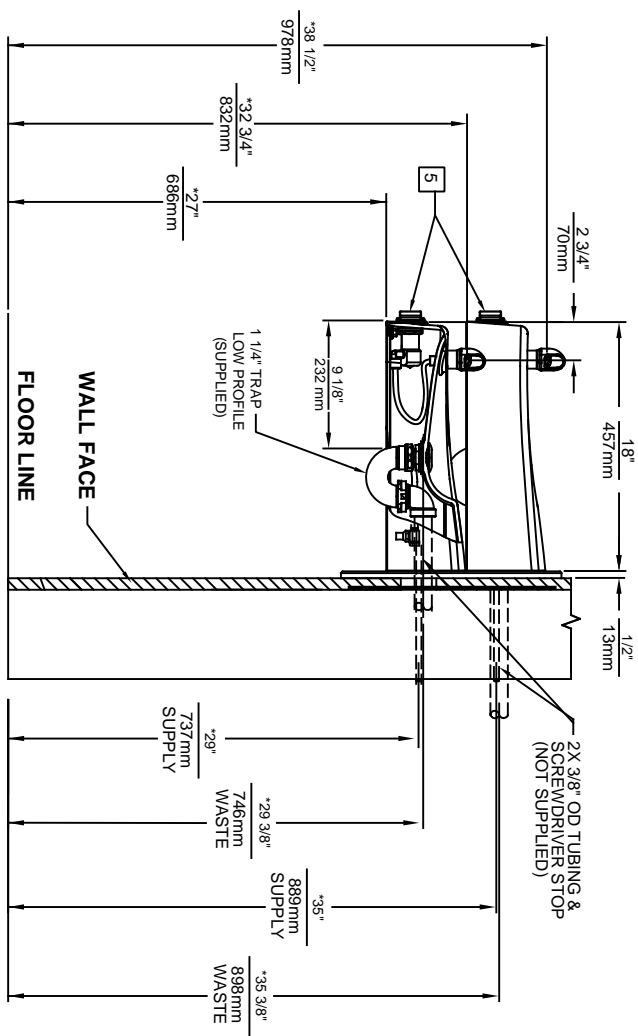
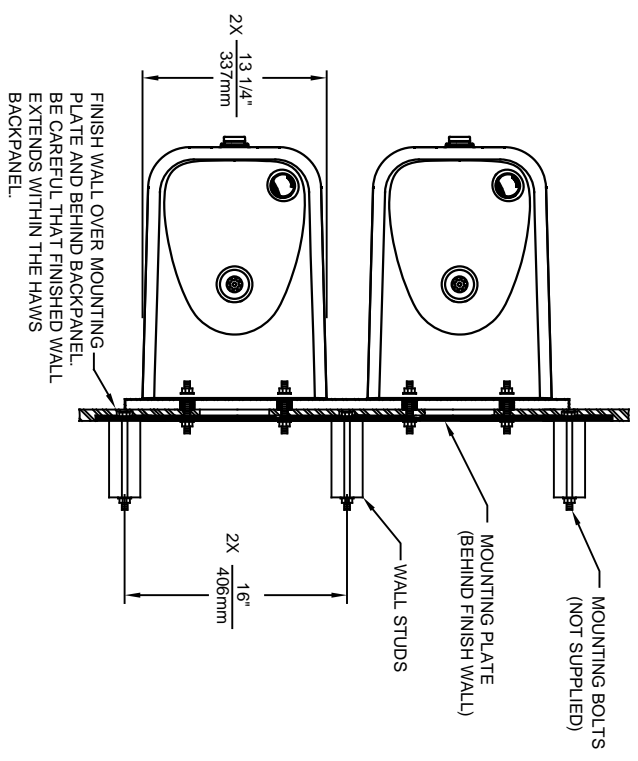
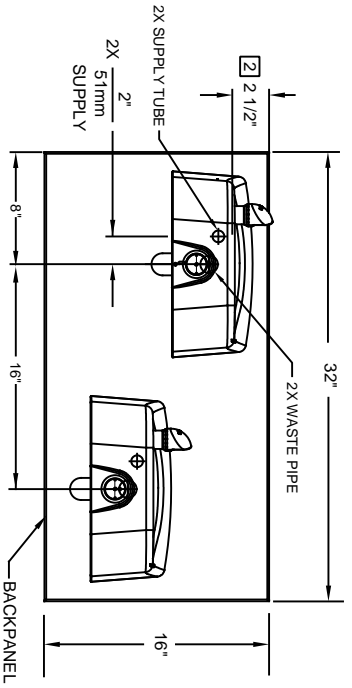

1459 KLEPPE LANE
 SPARKS, NEVADA 89431
 (775) 359-4712 FAX (775) 359-7424
 E-MAIL: HAWS@HAWS.CO.COM
 WEBSITE: WWW.HAWS.CO.COM

ECN NO. REVISED PER BY:	MODEL(S)	1501
5010 ECN: 5527 FV		
DATE: 08/25/15	CHKD: DP	
APPROVED: FV	DATE: 04/02/20	SCALE: 1:1
		DRAWING TYPE: INSTALLATION
		SIZE: A
		SHEET: 1 OF 1
		REVISION: 5
		PART NUMBER: 0510000047.D

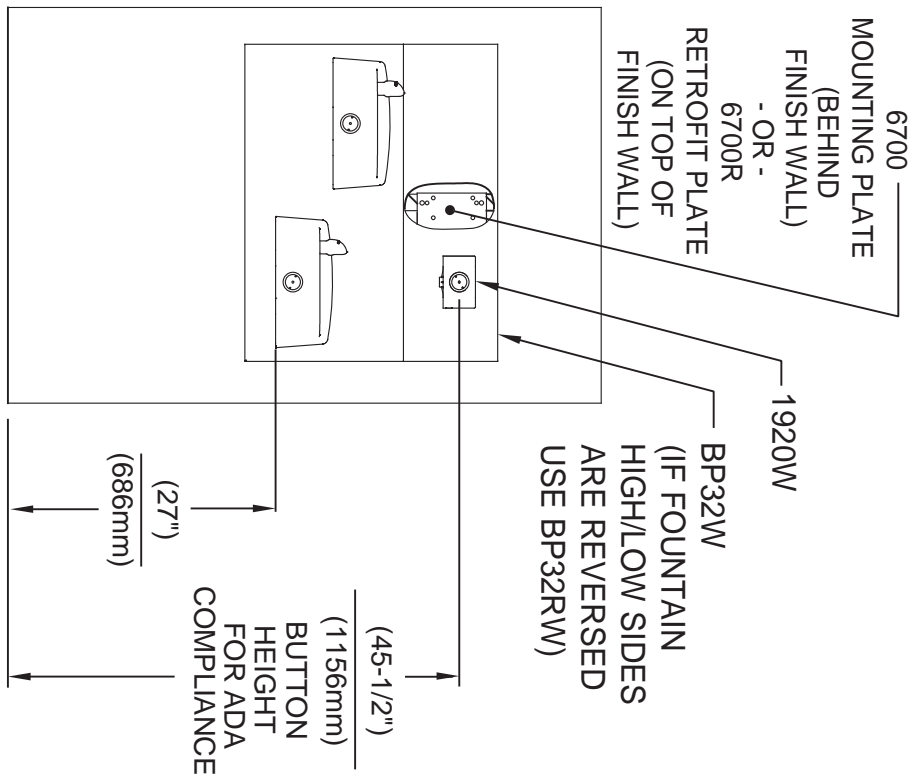

* IF YOUR FOUNTAIN IS THIS STYLE USE THESE DIMENSIONS

1. SEE SEPERATE INSTALLATION DRAWINGS FOR MOUNTING PLATES AND BACKPANELS
2. WHEN INSTALLING THIS UNIT, LOCAL, STATE OR FEDERAL CODES SHOULD BE ADHERED TO FOR INSTALLATION LOCATIONS, WASTE & SUPPLY REQUIREMENTS OTHER THAN SHOWN.

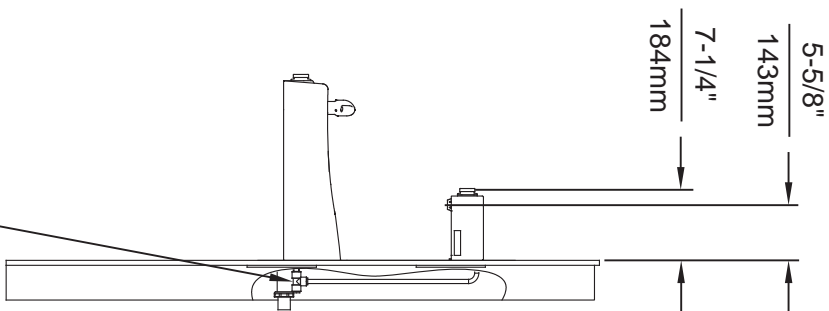
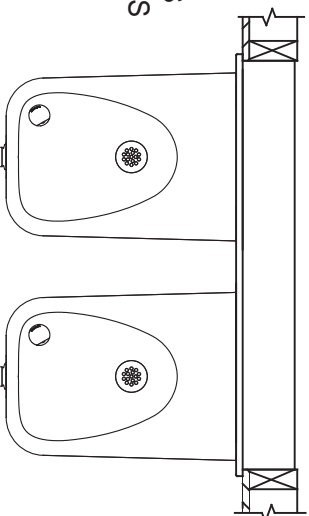

3/8" O.D. SUPPLY
TUBING AND 3/8" O.D.
PUSH-IN TEE SUPPLIED.
(CONNECT TO FOUNTAIN
SUPPLY LINE)

		1455 KLEPPE LANE SPARKS, NEVADA 89431 (775) 359-4712 FAX (775) 359-7424 E-MAIL: HAWS@HAWSCO.COM WEBSITE: WWW.HAWSCO.COM	
EQ. NO.	REVISED PER BY:	MODEL(S)	
5031	F.V.	1920W	
DRWN:	DATE:	SCALE:	DRAWING TYPE:
10/15/17	06/14/20	N/A	INSTALLATION
APPROVED:	DATE:	SCALE:	DRAWING TYPE:
F.V.	06/14/20	N/A	INSTALLATION
PART NUMBER	REVISION	SHEET	SHEET
0510000490.D	6	5	6

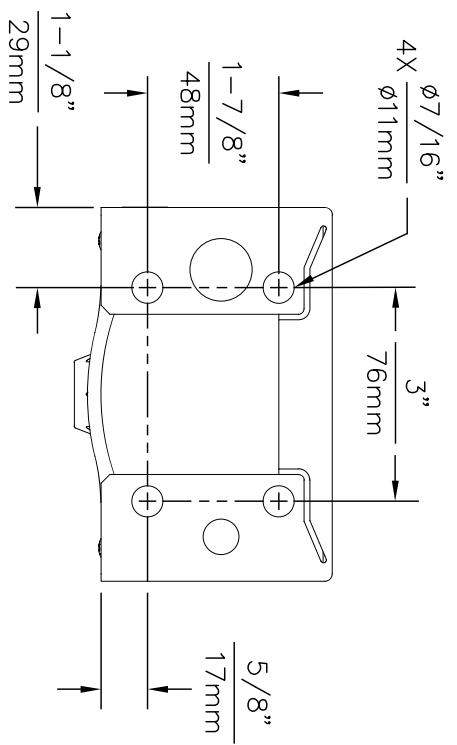
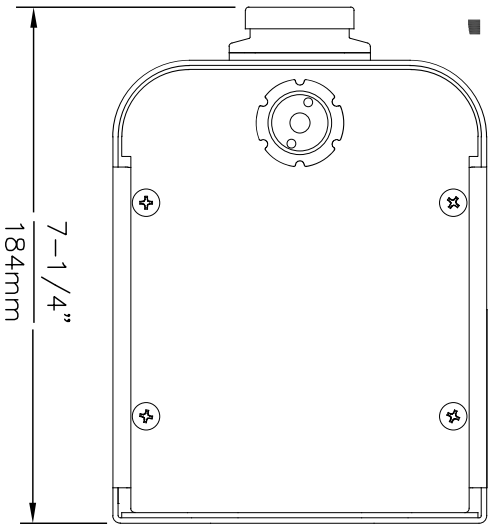
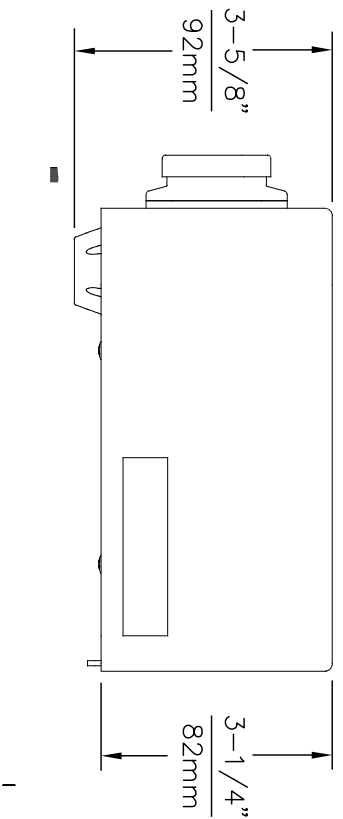

1920 MOUNTING HOLE LOCATIONS

NOTES:

1. SEE SEPERATE INSTALLATION DRAWINGS FOR MOUNTING PLATES AND BACKPANELS
2. WHEN INSTALLING THIS UNIT, LOCAL, STATE OR FEDERAL CODES SHOULD BE ADHERED TO FOR INSTALLATION LOCATIONS, WASTE & SUPPLY REQUIREMENTS OTHER THAN SHOWN.

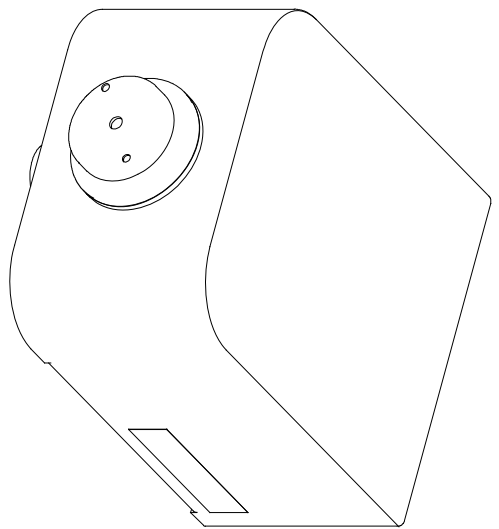

Haws

1455 KLEPPE LANE
SPARKS, NEVADA 89431
(775) 359-4712 FAX (775) 359-7424
E-MAIL: HAWS@HAWS.CO.COM
WEBSITE: WWW.HAWS.CO.COM

EGNO: HENSGP/PR/RY	MODEL(S)	MODEL 1920/1920HPS/1920W
DRAWN: EN:SLZ/ML	SCALE: NA	DRAWING TYPE: INSTALLATION
DATE: CHK/D	SIZE: A	SHEET 1 OF 5
DS: 05/25/16	REVISION	2
APPROVED: RV	DATE: 02/27/17	

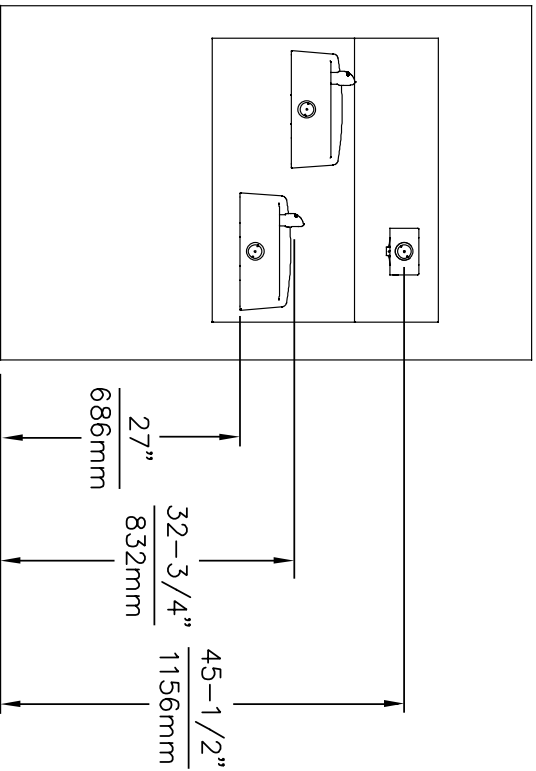

ADA ADULT ACCESSIBLE DIMENSIONS 1501 AND 1311
 DIMENSIONS ALSO APPLY TO SINGLE FOUNTAIN MODEL 1311 (NOT SHOWN)

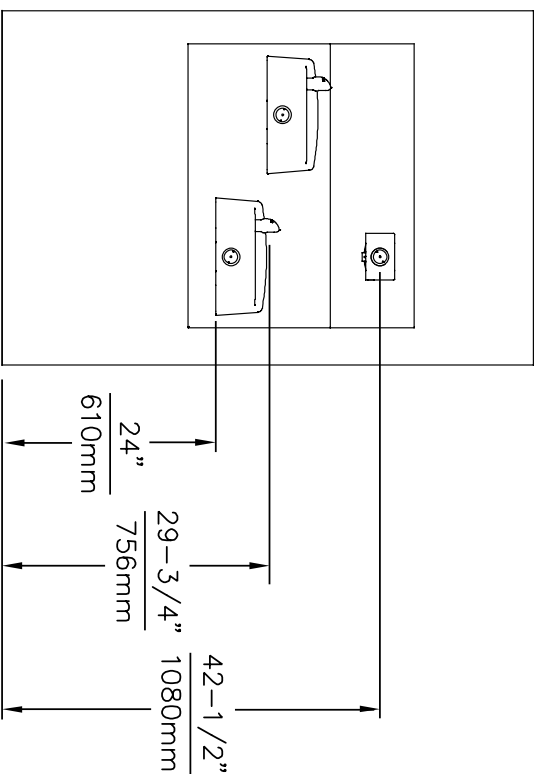

ADA CHILD ACCESSIBLE DIMENSIONS 1501 AND 1311
 DIMENSIONS ALSO APPLY TO SINGLE FOUNTAIN MODEL 1311 (NOT SHOWN)

		Haws		1455 KLEPPE LANE	
SPARKS, NEVADA, 89431		(775) 359-4712 FAX (775) 359-7424		E-MAIL: HAWS@HAWS.CO.COM	
WEBSITE: WWW.HAWS.CO.COM		ECON. REVISED PER BY:		MODEL(S)	
DRAWN: GJC	DATE: 08/13/17	DATE: QHND:	DATE:	MODEL 1501 AND 1311	
APPROVED:	DATE:	SCALE: NA	DRAWING TYPE:	WITH MODEL 1920 BOTTLE FILLER	
INSTALLATION		SIZE: A	SHEET: 1	OF: 1	
PART NUMBER:		REVISION:		1501-24	
QA.1					

THIS DOCUMENT IS TRUE AND CORRECT AT TIME OF PUBLICATION. CONTINUED PRODUCT IMPROVEMENTS MAKE SPECIFICATIONS AND MEASUREMENTS SUBJECT TO CHANGE WITHOUT NOTICE.

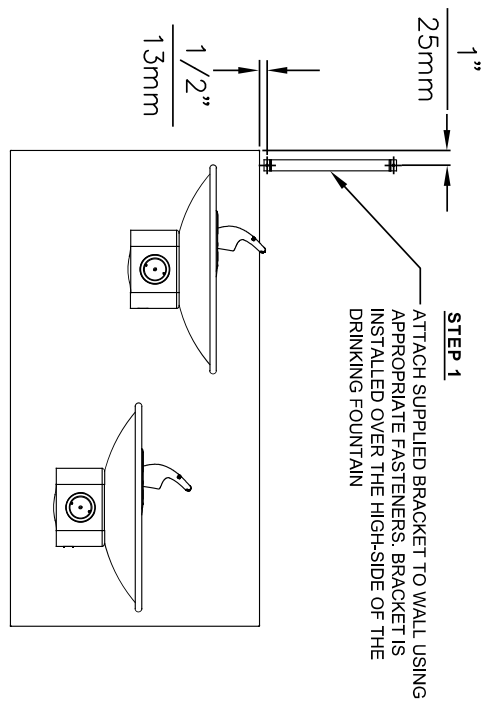

STEP 1
ATTACH SUPPLIED BRACKET TO WALL USING APPROPRIATE FASTENERS. BRACKET IS INSTALLED OVER THE HIGH-SIDE OF THE DRINKING FOUNTAIN

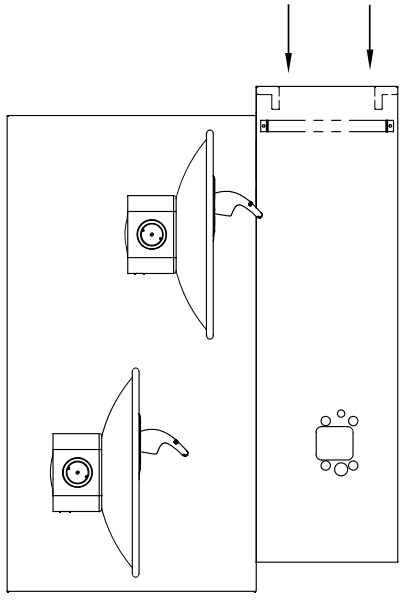

STEP 2
PLACE THE BACKPLATE AGAINST THE WALL AND SLIDE SIDEWAYS SO THE TABS CATCH UNDER THE BRACKET

STEP 3
INSTALL THE BOTTLE FILLER PER THE INSTRUCTIONS SUPPLIED WITH THE UNIT

NOTES:
1. WHEN INSTALLING THIS UNIT, LOCAL, STATE OR FEDERAL CODES SHOULD BE ADHERED TO.

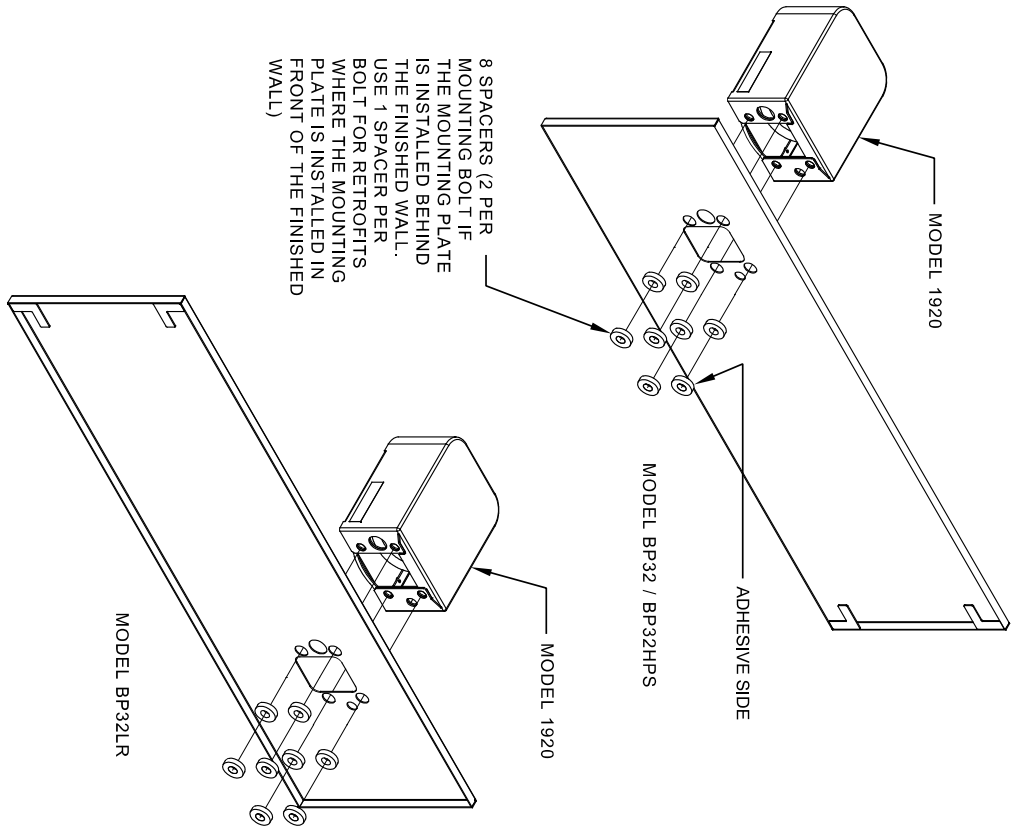

8 SPACERS (2 PER MOUNTING BOLT IF THE MOUNTING PLATE IS INSTALLED BEHIND THE FINISHED WALL. USE 1 SPACER PER BOLT FOR RETROFITS WHERE THE MOUNTING PLATE IS INSTALLED IN FRONT OF THE FINISHED WALL)

INSTALLATION OVER DOUBLE FOUNTAIN
SHOWN FROM REAR

		1455 KLEPPE LANE	
		SPARKS, NEVADA 89431	
		(775) 359-4712 FAX (775) 359-7424	
		E-MAIL: HAWS@HAWSCCO.COM	
		WEBSITE: WWW.HAWSCCO.COM	
ECN NO. 5081	REVISED PER BY: MJ	MODEL(S)	
DRAWN DATE: 08/17/17	CRD: FV	DRAWING, BACK PANEL SPACER INST., BF	
APPROVED DATE: 02/27/17	SCALE: 1:1	DRAWING TYPE: INSTALLATION	
FV		SIZE: A	SHEET: 2 OF 2
			REVISION: 2
			PART NUMBER: 05100004931D