



INSTALLATION, OPERATION & MAINTENANCE INSTRUCTIONS

1455 Kleppe Lane ♦ Sparks, NV 89431-6467 ♦ (775) 359-4712 ♦ Fax (775) 359-7424
E-mail: haws@hawsco.com ♦ website: www.hawsco.com

No. 0002076418 (21)

Model 1047 Drinking Fountain

NOTE TO INSTALLER: Please leave this information with the Maintenance Department.

LIMITED WARRANTY

HAWS warrants that this specific product is guaranteed against defective material or poor workmanship for a period of **one year from date of shipment**. HAWS liability under this warranty shall be discharged by furnishing without charge F.O.B. HAWS Factory any goods, or part thereof, which shall appear to the Company upon inspection to be of defective material or not of first class workmanship, provided that claim is made in writing to Haws within a reasonable period after receipt of the product. Where claims for defects are made, the defective part or parts shall be delivered to the Company, prepaid, for inspection. HAWS will not be liable for the cost of repairs, alterations or replacements, or for any expense connected therewith made by the owner or his agents, except upon written authority from HAWS, Sparks, Nevada. HAWS will not be liable for any damages caused by defective materials or poor workmanship, except for replacements, as provided above. Buyer agrees that HAWS shall not be liable for general, special, or consequential damages claimed to arise under the contract of sale. The drinking fountain manufactured by HAWS is warranted to function if installation and maintenance instructions provided are adhered to. The units also must be used for the purpose for which they were intended.

**NO OTHER WARRANTIES EXPRESSED OR IMPLIED ARE AUTHORIZED,
PROVIDED OR GIVEN BY HAWS.**

**SHOULD YOU EXPERIENCE DIFFICULTY WITH THE INSTALLATION OF THIS
MODEL PLEASE CALL:**

TECHNICAL SUPPORT: 1-800-766-5612

FOR CUSTOMER SERVICE: 1-888-640-4297

RECOMMENDED TOOLS: Hack saw, pipe joint sealant, screwdriver, level, 12" adjustable wrench, 10" pipe wrench, 5/64" hex key wrench, 9/16", 1/2", 7/16" socket wrench or open end wrench.

LOCATION OF UNIT: The Model 1047 Drinking Fountain is a wheelchair accessible drinking water facility. The height dimensions shown meet current ADA requirements. When installing this unit, local, state or federal codes should be adhered to. If height other than shown is required, then dimensions must be adjusted accordingly.

SUPPLY LINE: The minimum recommended line size is 1/2"IPS with 30-90 psi (2-6 ATM) flowing pressure. Where sediment or mineral content is a problem, an inlet filter is recommended.

PLUMBING CONNECTIONS: Inlet is 3/8"O.D. compression fitting. Waste outlet is female 1-1/2" IPS.

MAINTENANCE: Periodically clean the strainer. Refer to 5874 Series Valve Manual for more information.

TROUBLESHOOTING	
PROBLEM	REPAIR CHECKLIST
1 Insufficient bubbler flow.	1. a. Check that inlet screwdriver stop valve is in wide-open position. b. Verify minimum 30 psi supply pressure. c. Clean strainer. See 5874 Series Valve Manual d. Adjust valve to increase flow. Use front adjust screw or see 5874 Series Valve Manual.

General Notes:

Before tightening nut and ferrule assembly, push tubing into fitting until it bottoms out to ensure correct engagement with O-Ring.

For more information about Haws products, see our website: www.hawSCO.com

ITEM	DESCRIPTION	1047
1	STRAINER, WASTE ASSEMBLY	6466
2	BUTTON, PUSH, RECESSED, PCP W/ VALVE	5874PB
3	VALVE REPAIR KIT	VRK5874
4	BUTTON ASSEMBLY, PUSH, 5874	PBA7
5	BUBBLER HEAD ASSEMBLY, PCP	5703M
6	PLATE, BOTTOM	PBM1047
7	TRAP	0005987000
** 8	MOUNTING PLATE	6700

NOTES:

- 1 5874PB (ITEM 2) INCLUDES VRK5874 CARTRIDGE ASSEMBLY (ITEM 3) AND PBA7 RECESSED PUSH BUTTON (ITEM 4).
- 2 ENSURE TUBE IS DISCONNECTED FROM PUSH BUTTON VALVE BODY PRIOR TO REMOVAL. APPLY ONE DROP OF LOCTITE 222MS TO NOZZLE THREADS PRIOR TO FASTENING BACK ONTO BUBBLER HEAD. RE-ATTACH TUBE TO VALVE.

**

** REQUIRED - SOLD SEPARATELY.

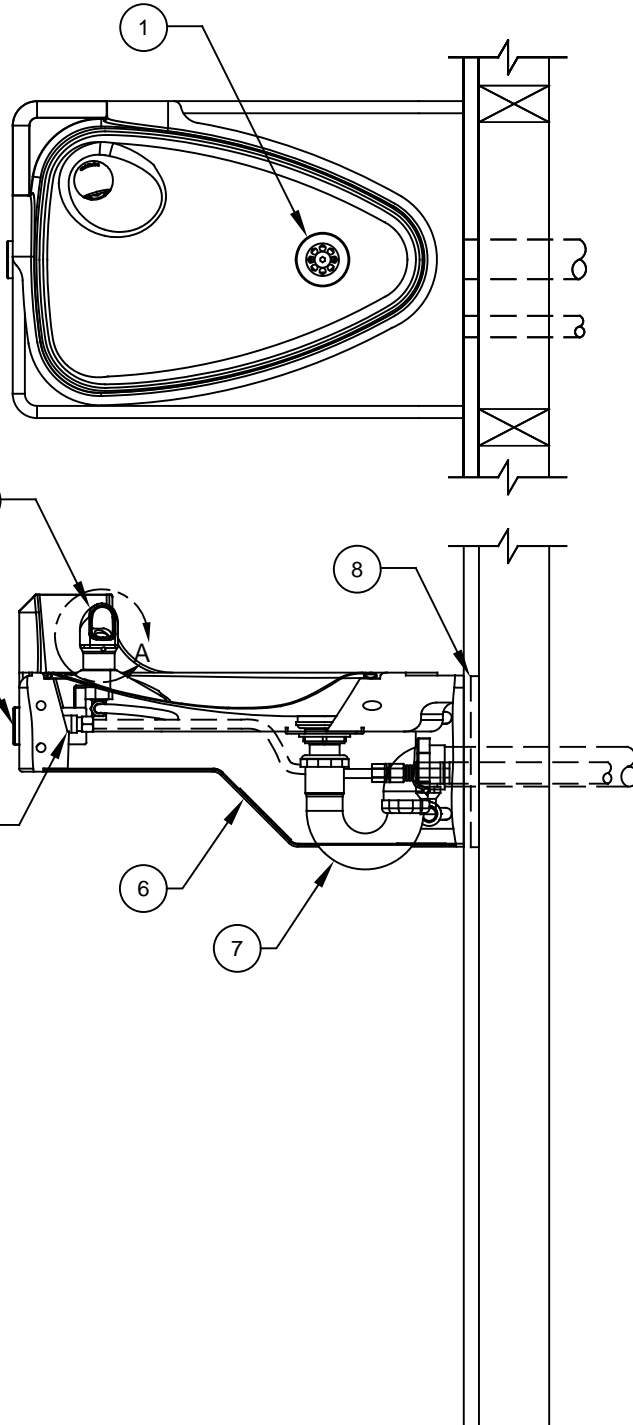

- 2 REMOVE INSERT WITH 5/16 HEX SOCKET (NOT SUPPLIED)

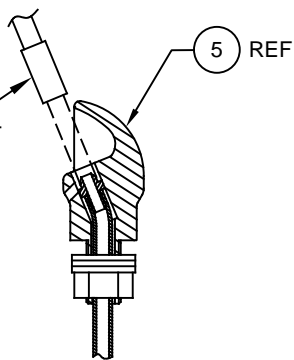

DETAIL A
ROTATED 90° INTO VIEW

PARTS BREAKDOWN

WHEN ORDERING PARTS PLEASE SPECIFY MODEL NUMBER.

		1455 KLEPPE LANE SPARKS, NEVADA 89431 (775) 359-4712 FAX (775) 359-7424 E-MAIL: HAWS@HAWS.CO.COM WEBSITE: WWW.HAWS.CO.COM	
		ECN NO. REVISED PER BY ECN: 5527 FV	MODEL(S) 1047
DRAWN D. OLLOM	DATE 11/25/95	CHKD DP	REVISION 21
APPROVED FV	DATE 04/02/20	SCALE: 1:1	DRAWING TYPE: PARTS BREAKDOWN SIZE: A SHEET 1 OF 1

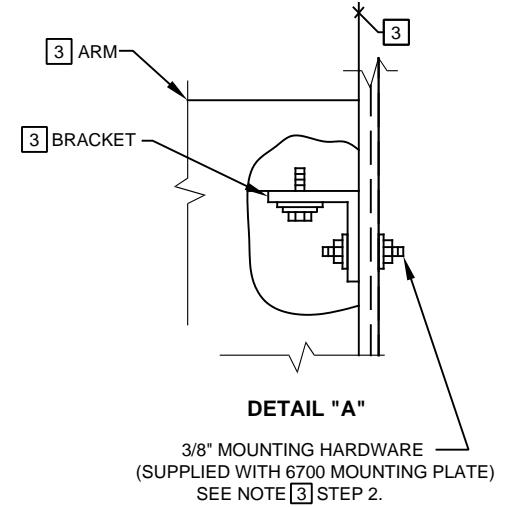
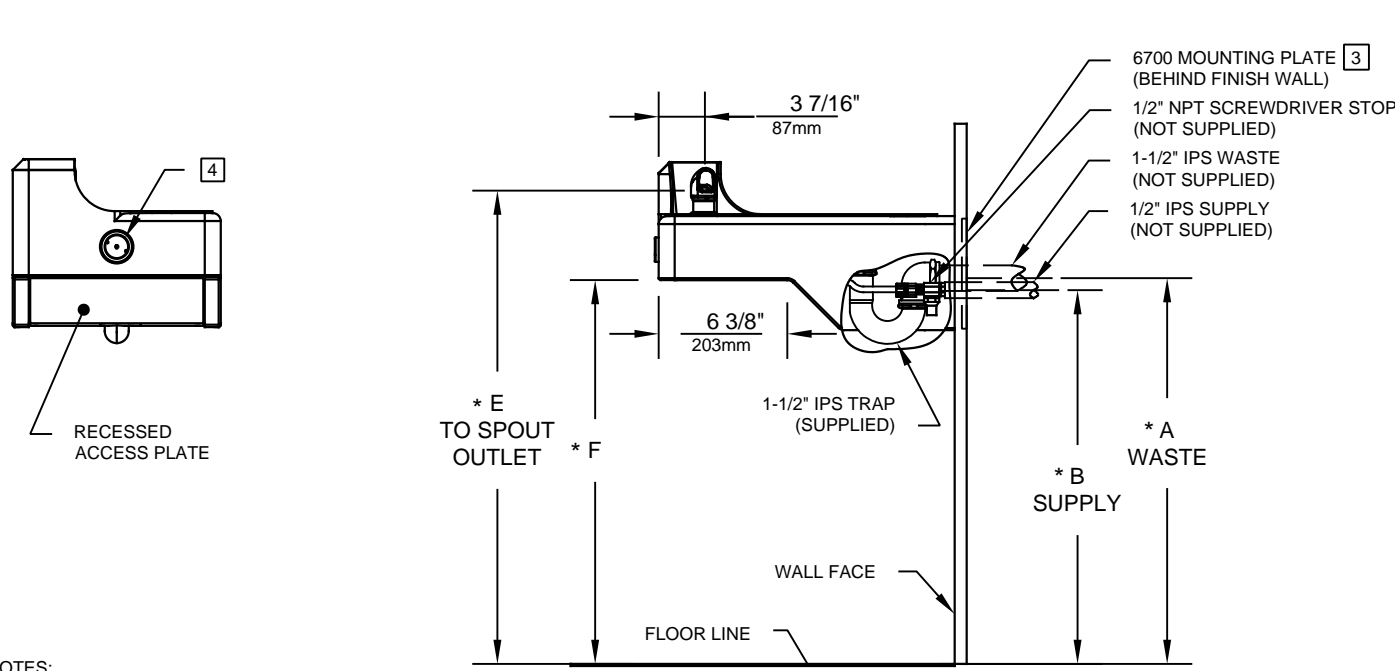
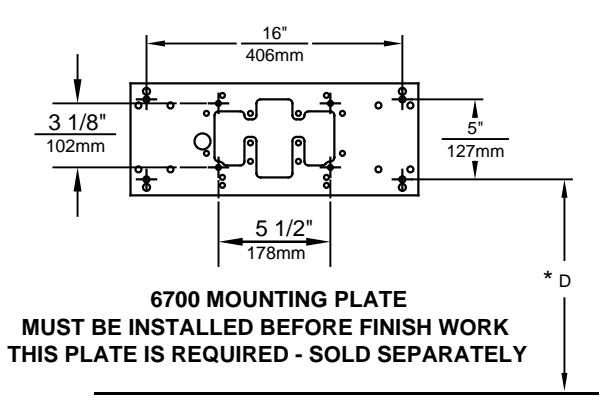
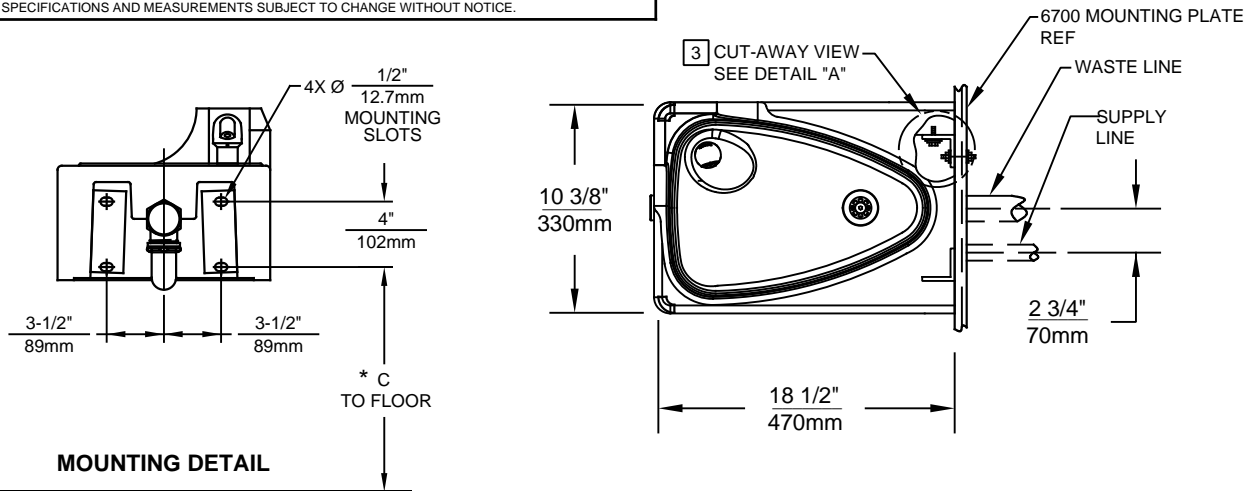

NOTES:

1. HOLD ROUGH-IN DIMENSIONS $\pm 1/4"$ (6.4mm).
2. WHEN INSTALLING THIS UNIT, LOCAL, STATE OR FEDERAL CODES SHOULD BE ADHERED TO. FOR INSTALLATION HEIGHTS OTHER THAN SHOWN, DIMENSIONS MARKED (*) MUST BE ADJUSTED ACCORDINGLY.
3. **PROCEDURE FOR ASSEMBLING ARM TO WALL:**
IMPORTANT: L-BRACKETS ARE PRE-ASSEMBLED AND **MUST NOT** BE LOOSENER FOR ANY REASON.
STEP 1: ATTACH ENTIRE ARM ASSEMBLY TO WALL USING 6700 MOUNTING PLATE (SUPPLIED) USING THE 3/8"-16 X 4" THREADED RODS, WASHERS AND NUTS (SUPPLIED WITH 6700 MTG PLT) AND TIGHTEN SECURELY IN PLACE.
STEP 2: (OPTIONAL) APPLY CAULKING AS NEEDED TO FILL ANY GAP PRESENT BETWEEN ARM AND PEDESTAL.
4. REFER TO 5874 SERIES OPERATION AND MAINTENANCE MANUAL FOR PUSH BUTTON AND VALVE INSTALLATION/MAINTENANCE INSTRUCTIONS.

DIM	ADULT ADA	CHILD ADA
A	27-1/2" / 699mm	24-1/2" / 622mm
B	26-3/8" / 670mm	23-3/8" / 594mm
C	25-1/8" / 638mm	22-1/8" / 562mm
D	24-3/8" / 619mm	21-3/8" / 543mm
E	32-3/4" / 832mm	29-3/4" / 756mm
F	27" / 686mm	24" / 610mm

1455 KLEPPE LANE
 SPARKS, NEVADA 89431
 (775) 359-4712 FAX (775) 359-7424
 E-MAIL: HAWS@HAWSCO.COM
 WEBSITE: WWW.HAWSCO.COM

ECN NO. 4144	REVISED PER ECN: 5527	BY: FV	MODEL(S)	PART NUMBER
DRAWN: SLS	DATE: 07/22/08	CHKD.: DP	1047	0002076418.D
APPROVED: FV	DATE: 04/02/20	SCALE: N/A	DRAWING TYPE: INSTALLATION	REVISION 21
			SIZE: A	SHEET 1 OF 1