



INSTALLATION, OPERATION & MAINTENANCE INSTRUCTIONS

1455 Kleppe Lane ♦ Sparks, NV 89431-6467 ♦ (775) 359-4712 ♦ Fax (775) 359-7424
E-mail: haws@hawsco.com ♦ website: www.hawsco.com

No. 0002076519 (12)

Model 1011MS/1011HPSMS Drinking Fountain

NOTE TO INSTALLER: Please leave this information with the Maintenance Department.

LIMITED WARRANTY

HAWS warrants that this specific product is guaranteed against defective material or poor workmanship for a period of **one year from date of shipment**. HAWS liability under this warranty shall be discharged by furnishing without charge F.O.B. HAWS Factory any goods, or part thereof, which shall appear to the Company upon inspection to be of defective material or not of first class workmanship, provided that claim is made in writing to Haws within a reasonable period after receipt of the product. Where claims for defects are made, the defective part or parts shall be delivered to the Company, prepaid, for inspection. HAWS will not be liable for the cost of repairs, alterations or replacements, or for any expense connected therewith made by the owner or his agents, except upon written authority from HAWS, Sparks, Nevada. HAWS will not be liable for any damages caused by defective materials or poor workmanship, except for replacements, as provided above. Buyer agrees that HAWS shall not be liable for general, special, or consequential damages claimed to arise under the contract of sale. The drinking fountain manufactured by HAWS is warranted to function if installation and maintenance instructions provided are adhered to. The units also must be used for the purpose for which they were intended.

NO OTHER WARRANTIES EXPRESSED OR IMPLIED ARE AUTHORIZED, PROVIDED OR GIVEN BY HAWS.

SHOULD YOU EXPERIENCE DIFFICULTY WITH THE INSTALLATION OF THIS MODEL PLEASE CALL:

TECHNICAL SUPPORT: 1-800-766-5612

FOR CUSTOMER SERVICE: 1-888-640-4297

RECOMMENDED TOOLS: Hack saw, pipe joint sealant, screwdriver, level, 12" adjustable wrench, 10" pipe wrench, 5/32" hex key wrench, 9/16", 1/2", 7/16" socket wrench or open end wrench.

LOCATION OF UNIT: When installing Model 1011HPSMS/1011MS Drinking Fountain is a wheelchair accessible drinking water facility. The height dimensions shown, meet current ADA requirements. When installing this unit, local, state or federal codes should be adhered to. If height other than shown is required, then dimensions must be adjusted accordingly.

SUPPLY LINE: The minimum recommended line size is 1/2"IPS with 30-90 psi (2-6 ATM) flowing pressure. Where sediment or mineral content is a problem, an inlet filter is recommended.

PLUMBING CONNECTIONS: Inlet is 3/8" O.D. push-in type fitting. Waste outlet is 1-1/4" O.D. tube.

MAINTENANCE: Periodically clean the strainer. Refer to 5874 Series Valve Manual for more information.

TROUBLESHOOTING

PROBLEM	REPAIR CHECKLIST
1. Insufficient bubbler flow.	1a. Check that inlet screwdriver stop valve (not supplied) is wide open. b. Verify minimum 30 psi flowing supply pressure. c. Clean strainer. See 5874 Series Valve Manual. d. Adjust valve to increase flow. Use front adjust screw or see 5874 Series Valve manual.

GENERAL NOTES:

1. For all plastic push-in type fitting connections, only connect NSF-61 copper or plastic tubing. Stainless steel or glass tubing is not recommended. The following assembly instructions must be followed to ensure a watertight connection:
 - a. Cut tubing square and clean.
 - b. Mark from end of tube the length of insertion (See table below).
 - c. Push tube into the fitting until it bottoms out.
 - d. To remove, depress collet and pull tubing out.

Tube Sizes	O.D. Tolerance	Insertion Depth
1/4"	±.005"	11/16"
3/8"	±.005"	3/4"
1/2"	±.005"	7/8"

For more information about Haws products, see our website: www.hawSCO.com

NOTES:

- 1 5874PBF (ITEM 2) INCLUDES VRK5874 CARTRIDGE ASSEMBLY (ITEM 3) AND PBA6 FLANGED PUSH BUTTON (ITEM 4).

ITEM	DESCRIPTION	1011	1011HPS
1	BUBBLER HEAD, PCP	5705	5705
2	BUTTON, PUSH, PCP, FLANGED W/ VALVE	5874PBF	5874PBF
3	VALVE REPAIR KIT	VRK5874	VRK5874
4	BUTTON, PUSH, 5874, FLANGED	PBA6	PBA6
5	PANEL, BACK, F/ SATIN SWIRL OR HI-POL SS	0004012000	0004012023
**	FRAME, MOUNTING	MTGFR.DF2	MTGFR.DF2
7	STRAINER, WASTE ASSEMBLY, SCP OR PCP	6463	6463PCP
*	PANEL, ACCESS, SS SATIN OR HI-POL	6608	6608HPS
9	PLATE, BOTTOM, F/1000	PBM1000	PBM1000
10	INSERT, LAMINAR FLOW, 5705	0002850230	0002850230
*	DRIVER, NOZZLE, .25 HEX	0002082253	0002082253

* DENOTES OPTIONAL PART.
 ** REQUIRED - SOLD SEPARATELY.

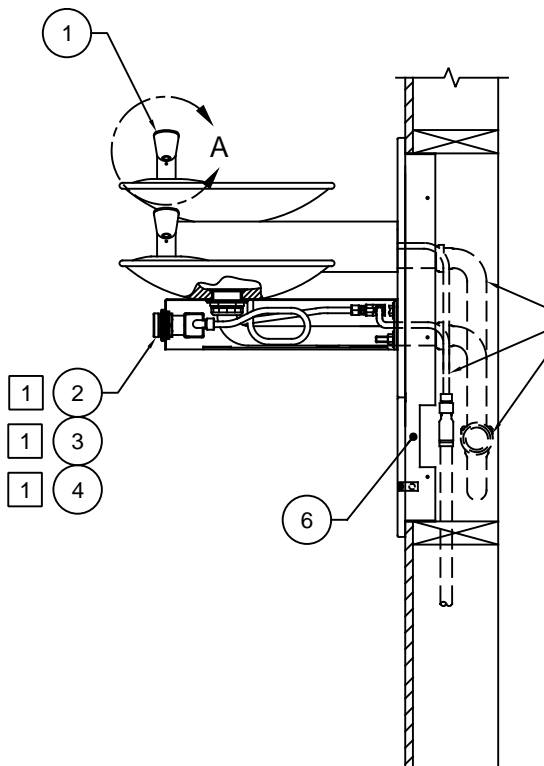

(NOT SUPPLIED)

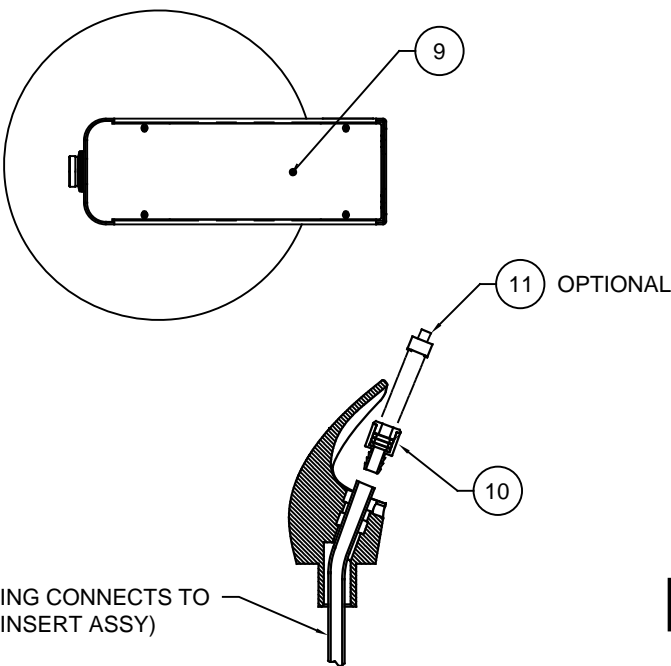

DETAIL A
(ROTATED 90° INTO VIEW)

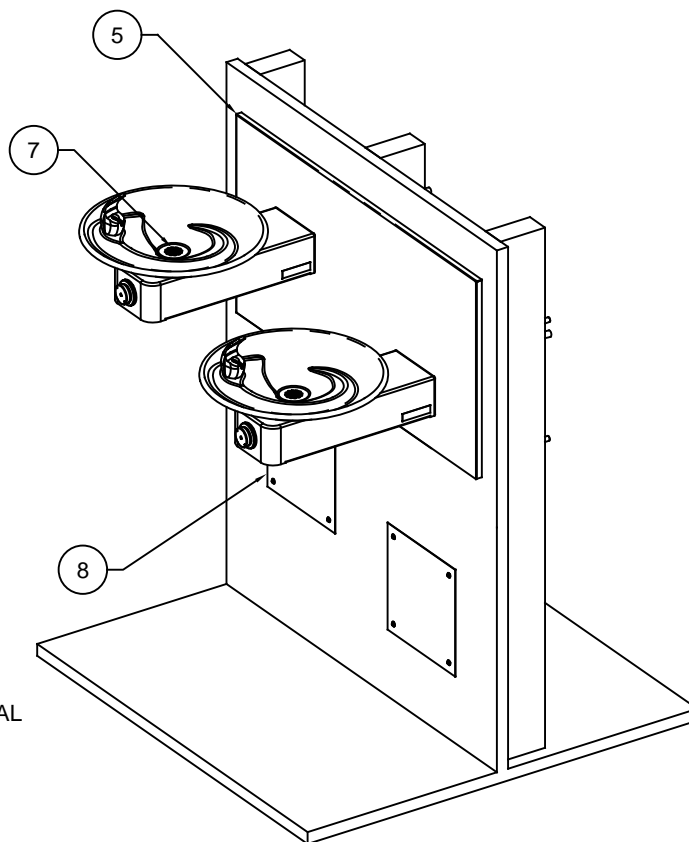

PARTS BREAKDOWN

WHEN ORDERING PARTS PLEASE SPECIFY MODEL NUMBER.

		1455 KLEPPE LANE SPARKS, NEVADA 89431 (775) 359-4712 FAX (775) 359-7424 E-MAIL: HAWS@HAWSCO.COM WEBSITE: WWW.HAWSCO.COM	
ECN NO.	REVISED PER	BY	MODEL(S)
.	ECN: 5527	FV	1011MS/1011HPSMS
DRAWN	DATE	CHKD	PART NUMBER
PM	08/02/99	DP	0002076519
APPROVED	DATE		REVISION
FV	04/02/20		12
SCALE: 1:8		DRAWING TYPE: PARTS BREAKDOWN	SIZE: A SHEET 1 OF 1

NOTES:

- 1 HOLD ROUGH-IN DIMENSIONS $\pm 1/8"$ (3.2mm).
- 2 WHEN INSTALLING THIS UNIT, LOCAL, STATE, OR FEDERAL CODES SHOULD BE ADHERED TO FOR DIMENSIONS (LOCATIONS), WASTE AND SUPPLY REQUIREMENTS OTHER THAN SHOWN.
- 3 INSTALLER MUST PROVIDE TRAP FOR PROPER INSTALLATION.
- 4 HOLE COMBINATION SHOWN BELOW IS FOR USE WITH LOW FOUNTAIN ON THE RIGHT AND HIGH FOUNTAIN ON THE LEFT. USE OPPOSITE HOLES FOR HIGH ON RIGHT AND LOW ON LEFT.
- 5 TO CHANGE FOUNTAIN MTG. SCREW LOCATIONS: FIRST REMOVE SCREWS AND THEN SQUEEZE CLIPS ON NUT RETAINER TO POP OUT. SNAP INTO NEW POSITIONS FROM BACKSIDE AND RE-ASSEMBLE SCREWS.
- 6 IMPORTANT: A L.H. LOW (OPTIONAL) CONFIGURATION WILL REQUIRE A DIFFERENT BACK PANEL AND THE WASTE AND SUPPLY DIMENSIONS SHOWN (*) MUST BE REVERSED.
- 7 REFER TO 5874 SERIES OPERATION AND MAINTENANCE MANUAL FOR PUSH BUTTON AND VALVE INSTALLATION/MAINTENANCE INSTRUCTIONS.

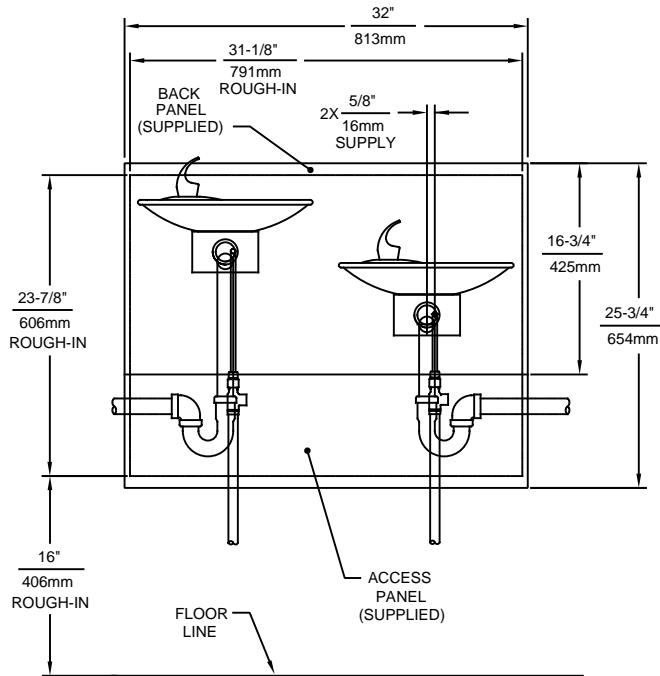
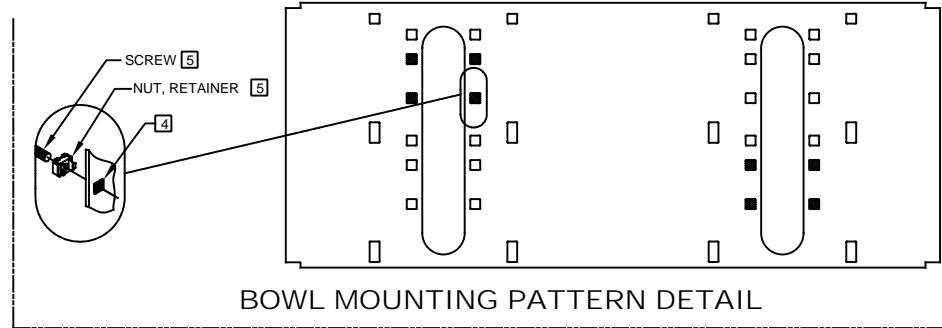
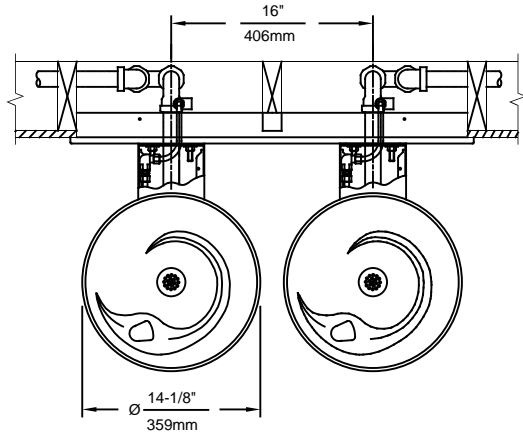

REMOVE VALVE FROM PUSH BUTTON TO INSTALL WASTE ELBOW ONTO BOWL. AFTER WASTE ELBOW IS INSTALLED, REINSTALL VALVE & ADJUST FLOW

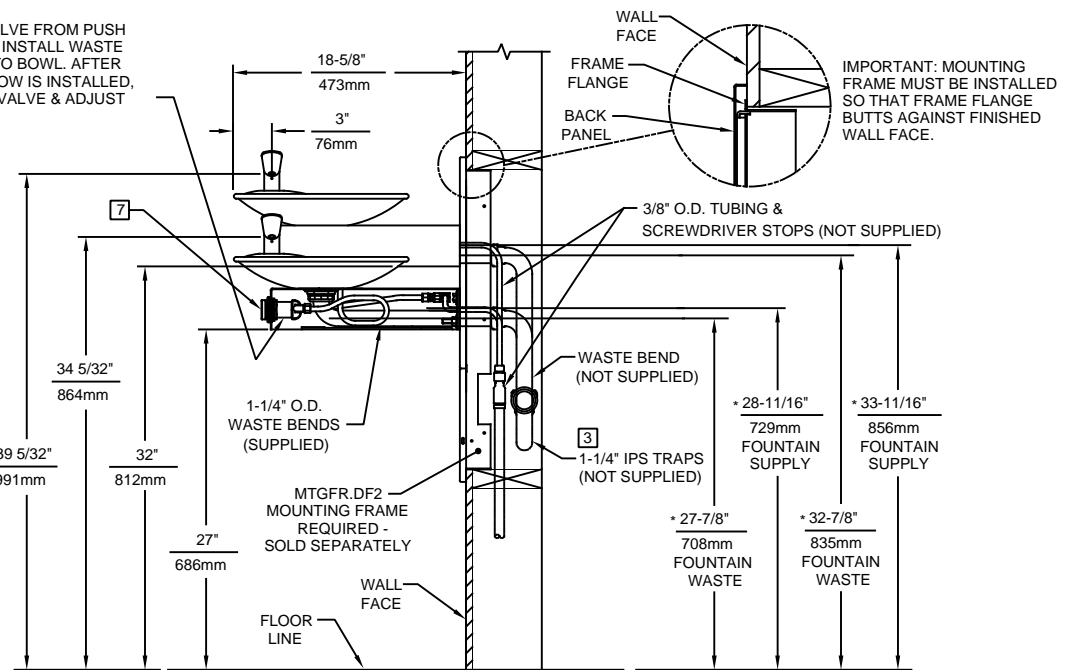

IMPORTANT: MOUNTING FRAME MUST BE INSTALLED SO THAT FRAME FLANGE BUTTS AGAINST FINISHED WALL FACE.

1455 KLEPPE LANE
SPARKS, NEVADA 89431
(775) 359-4712 FAX (775) 359-7424
E-MAIL: HAWS@HAWSCO.COM
WEBSITE: WWW.HAWSCO.COM

ECN NO.	REVISED PER	BY:	MODEL(S)	PART NUMBER
	ECN: 5527	FV		0002076519.D
DRAWN: PM	DATE: 08/02/99	CHKD: DP	1011MS/1011HPSMS	REVISION
APPROVED: FV	DATE: 04/02/20			12
SCALE: 1:16		DRAWING TYPE: INSTALLATION		SIZE: A SHEET 1 OF 1