



INSTALLATION, OPERATION & MAINTENANCE INSTRUCTIONS

1455 Kleppe Lane ♦ Sparks, NV 89431-6467 ♦ (775) 359-4712 ♦ Fax (775) 359-7424
E-mail: haws@hawsco.com ♦ website: www.hawsco.com

No. 2080249(16)

Model H1011.8/H1011.8HPS Water Cooler

NOTE TO INSTALLER: Please leave this information with the Maintenance Department.

Haws electric water coolers are not designed or recommended for outdoor or corrosive environments such as enclosed chlorinated pool areas.

Consideration must be made at the time of installation to adhere to state and/or local codes and environmental/atmospheric conditions such as, but not limited to, dust, corrosion, freezing etc. These conditions will void the warranty.

CAUTION! Prior to making any electrical connections, verify with a voltmeter that power from the service panel is **off**.

LIMITED WARRANTY

HAWS® warrants that all of its products are guaranteed against defective material or poor workmanship for a period of **one year from date of shipment**. HAWS liability under this warranty shall be discharged by furnishing without charge F.O.B. HAWS Factory any goods, or part thereof, which shall appear to the Company upon inspection to be of defective material or not of first class workmanship, provided that claim is made in writing to company within a reasonable period after receipt of the product. Where claims for defects are made, the defective part or parts shall be delivered to the Company, prepaid, for inspection. HAWS will not be liable for the cost of repairs, alterations or replacements, or for any expense connected therewith made by the owner or his agents, except upon written authority from HAWS, Sparks, Nevada. HAWS will not be liable for any damages caused by defective materials or poor workmanship, except for replacements, as provided above. Buyer agrees that Haws has made no other warranties either expressed or implied in addition to those above stated, except that of title with respect to any of the products or equipment sold hereunder and that HAWS shall not be liable for general, special, or consequential damages claimed to arise under the contract of sale. The drinking fountain manufactured by HAWS is warranted to function if installation and maintenance instructions provided are adhered to. The units also must be used for the purpose for which they were intended.

NO OTHER WARRANTIES EXPRESSED OR IMPLIED ARE AUTHORIZED, PROVIDED OR GIVEN BY HAWS.

SHOULD YOU EXPERIENCE DIFFICULTY WITH THE INSTALLATION OF THIS MODEL PLEASE CALL:

TECHNICAL SUPPORT: 1-800-766-5612

FOR CUSTOMER SERVICE: 1-888-640-4297

RECOMMENDED TOOLS: Hack saw, pipe joint sealant, screwdriver, level, 12" adjustable wrench, 10" pipe wrench, 3/32" and 5/32 " hex key wrench, 9/16", 1/2", 7/16" socket wrench or open end wrench.

LOCATION OF UNIT: The Model H1011.8/H1011.8HPS Cooler is a wheelchair accessible drinking facility. The height dimensions shown, meet current ADA requirements. When installing this unit, local, state or federal codes should be adhered to. If height other than shown is required, then dimensions must be adjusted accordingly.

SUPPLY LINE: The minimum recommended line size is 1/2"IPS with 30-90 psi (2-6 ATM) flowing pressure. Where sediment or mineral content is a problem, an inlet filter is recommended.

PLUMBING CONNECTIONS: Inlet is 3/8" O.D. tube. Waste outlet is 1-1/4" O.D. tube.

ELECTRICAL CONNECTIONS: 115VAC, 60HZ, 4.7 AMPS. Chiller wired direct to incoming line, by others.

PARTS LIST		
MODEL PACKAGE	QUANTITY	ITEMS INCLUDED
MTGFR.LG	1	Mounting Frame
	3	#10 Sheet Metal Screws
HCR8	1	Chiller
H1011.8/H1011.8HPS	2	Bowl Assembly with push button valve
	1	Package supply tubing assembly with strainer, tubes and fittings
	1	Panel-bowl back
	1	Grille
	1	Package of two each-grille attachment clips, clip nuts, #10 sheet metal screws and 6-32 screws.
	2	Waste Elbow 1-1/4" O.D.
	8	5/16-18 retainer nuts
	8	5/16-18 x 1 hex head screws

INSTALLATION PROCEDURE

GENERAL NOTES:

The Model H1011.8/H1011.8HPS Water Cooler assembly requires installation of the mounting frame as described in Steps 1 - 2, then mounting the fountain bowl assembly as described in Steps 3 - 6, and finally completing chiller water and electrical connections and starting chiller per Steps 7 - 11. First check that all required parts are received.

Grounding may cause electrical feedback into the electric drinking fountain causing an electrolysis, which creates a metallic taste or an increase in the metal content of the water. This condition can be avoided by using dielectric couplings in the assembly. The waste line, which is supplied by the installer, should also have a dielectric (plastic) coupling to completely isolate the assembly from the building plumbing system.

For all plastic push-in type fitting connections; push tubing into fitting until it bottoms out to ensure a watertight connection. To remove, depress collet and pull tubing out.

- STEP 1:** Provide wall opening as detailed in Installation Drawing. Frame must be positioned such that frame flanges overlap and butt against finished wall surface. Mounting holes are provided for #6 sheet metal screws. After frame is positioned in wall, swing chiller support tray into position (See Installation Drawing), align tray holes with holes in frame and fasten with #10 sheet metal screws. Mounted frame must support 50 pound chiller in addition to fountain weight and user generated forces.
- STEP 2:** Install waste, supply and electrical lines in locations shown in Installation Drawing. Waste and supply lines may be installed for either rear or side entry. Verify proper waste, supply, electrical and frame locations. Use level to verify horizontal and vertical frame mounting to insure proper bowl drainage.
- STEP 3:** Installation Drawing shows fountain bowls, back panel and grille locations. Unpack bowls and remove bottom plate using 3/32" hex allen wrench. Install back panel on frame with narrower edge to bottom. Position nut retainers into mounting frame and use two 5/16-18x1 hex head screws partially started in outside holes to support panel. Install bowl/bracket assembly onto panel using eight 5/16-18x1 hex head screws hand tightened. See sheet 2 of Installation Drawing for appropriate bowl mounting pattern to use for this model.
- STEP 4:** Remove 1-1/2" IPS outlet elbow from traps (not supplied). Install elbow inside frame onto waste stub-outs. Reassemble trap "U" bends with inlets centered behind fountains.
- STEP 5:** Remove slip joint nuts from bottom of fountain waste outlets. Assemble nut over 1-1/4 O.D. end of longer waste elbow as supplied by Haws. Assemble waste elbows onto bowl waste body using seal washer provided and tighten nut hand tight. Measure vertical distance down to trap inlets and cut the vertical elbow (not supplied) to length allowing 1/2" minimum for engagement into trap. Mark and similarly cut to length the horizontal waste elbow. Install elbows and tighten slip joint nuts.

INSTALLATION PROCEDURE...

- STEP 6:** See Figure 1 for detail section view of side screw grille attachment. Unpack grille and insert upper lip behind bottom of back panel, align sides and hold up flush to bottom of back panel. Hold grille against wall and mark centers of grille side slots on wall. Masking tape may be used to prevent finished wall damage from mark. Install the "s" clips in mounting frame using #10 sheet metal screws into pre-drilled holes on lower end of each side of frame. Tighten #10 screw while holding "s" clips centered on wall marks. Check grille fit by installing grille and partially tightening #6-23 socket head screws through side of grille. Insure proper panel and grille alignment, then tighten eight 5/16-18x1 hex head screws.
- STEP 7:** Unpack and remove chiller from carton. Remove front panel screws and panel. Do not remove insulating putty and foam from copper tubes or Styrofoam insulation from evaporator coil. Remove any inner packing, which may be around compressor. If applicable, remove junction box cover and electrical knock out on lower right side of housing. Install fittings (supplied) on chiller inlet and outlet tubes (See Installation Drawing).

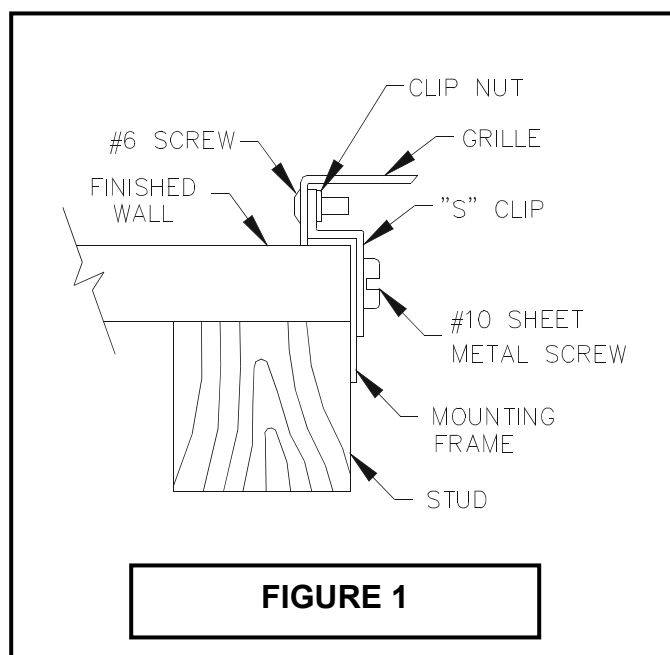

- STEP 8:** Thoroughly flush supply line to remove all foreign matter. Connect 1/2" IPS supply screwdriver stop (not supplied) to stub-out in wall. Place chiller on chiller support tray against right hand side, fully to rear, with condenser (open panel) side facing to front. Install supply (3/8" O.D.) tubing (not supplied), between screwdriver stop (not supplied) and chiller inlet. (Cut tubing to proper length, and follow general notes for proper connection procedures for push-in type fittings). Tubing insulation is not normally required on inlet side of chiller. Install insulated tube (supplied) between fountain and chiller outlet. Cut tubes as required and connect to chiller outlet compression fitting. Open screwdriver stop **wide open** while checking for leaks at all connections.
- STEP 9:** Adjust bubbler stream height using a small flat-head screwdriver inserted through a hole in the center of the push button for increased flow turn clockwise and for decreased flow turn counterclockwise. If flow problems arise, see troubleshooting guide for additional instructions to correct problem. Bubbler stream may lower during short break-in period. Set initial stream height a little high to minimize or eliminate the need for break-in period readjustment.

INSTALLATION PROCEDURE...

STEP 10: Verify that electrical power is off and power supply voltage, phase and cycle match specifications printed on chiller label. In accordance with local codes, wire directly to incoming lines at internal chiller junction box. Verify that all inner packing is removed and hand rotate fan blade to verify free rotation. Reattach chiller front panel. Turn power on and verify that chiller cycles off after water reaches proper temperature. Finally, check for leaks.

STEP 11: Install grille and tighten outer screws. Verify there is chilled water out of bubbler.

MAINTENANCE

STEP 1: Periodically clean the strainer located in the valve body. Refer to 5874SS Valve Manual for more information.

STEP 2: The condenser fins on chiller should be periodically cleaned with brush, air hose or vacuum cleaner. Care should be taken not to bend or deform the condenser fins.

STEP 3: The chiller temperature control is factory set for 50° F water under normal conditions. For colder water, adjust control clockwise. For warmer water, turn counterclockwise. Remove front chiller panel for access to temperature control. After adjustment allow unit to cycle off before checking outlet water temperature.

TROUBLESHOOTING	
PROBLEM	REPAIR CHECKLIST
1. Insufficient bubbler flow.	1a. Check that inlet screwdriver stop valve is in wide-open position. b. Verify minimum 30 psi flowing supply pressure. c. Clean strainer. See 5874SS Valve Manual. d. Adjust valve to increase flow. Use front adjust screw or see 5874SS Valve Manual.
2. Water too warm or cold.	a. Adjust chiller temperature control, clockwise for colder water.

General Notes:

For all plastic push-in type fitting connections; push tubing into fitting until it bottoms out to ensure a watertight connection. To remove, depress the collet and pull tubing out.

For more information about Haws products, see our website: www.hawSCO.com

PARTS BREAKDOWN

ITEM	MODEL		DESCRIPTION
	H1011.8	H1011.8HPS	
1	0006983506	0006983506	SPANNER WRENCH
2	5705	5705	BUBBLER HEAD W/INSERT (STYLE A OR STYLE B)
3	6463	6463PCP	STRAINER ASSY
4	PBA6	PBA6	PUSH BUTTON ASSY
5	5874SS	5874SS	VALVE
6	PBM1000	PBM1000	ACCESS PLATE
7	MTGFR.LG	MTGFR.LG	MOUNTING FRAME
8	HCR8	HCR8	CHILLER
9	0002626651	0002626665	GRILLE
10	0004012000	0004012023	BACK PANEL

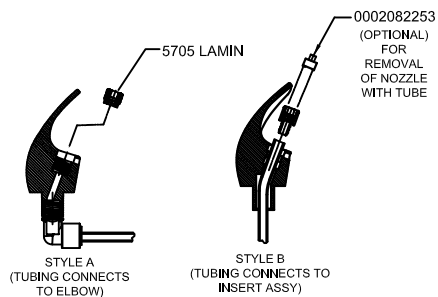
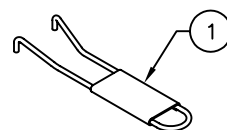
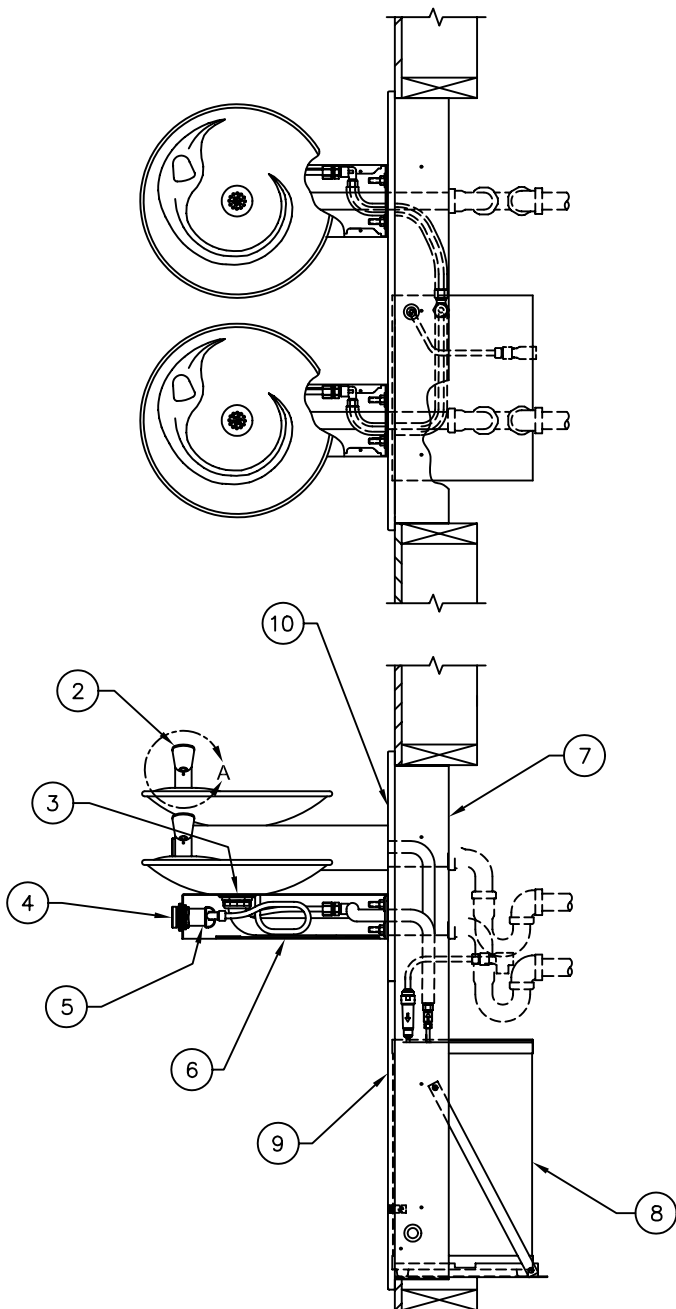

FOUNTAIN COULD HAVE EITHER STYLE

DETAIL A
ROTATED 90° INTO VIEW

		1455 KLEPPE LANE SPARKS, NEVADA 89431 (775) 359-4712 FAX (775) 359-7424 E-MAIL: HAWS@HAWS.CO.COM WEBSITE: WWW.HAWS.CO.COM	
		ECN NO: 4175 REVISED PER: HM DATE: 11/21/99 CHKD.:	MODEL(S) H1011.8/H1011.8HPS DRINKING FOUNTAIN
DRAWN: RTM APPROVED:		SCALE: 1/7 DRAWING TYPE: PARTS BREAKDOWN	DRAWING NO.: 13368C00 REV. 16

WHEN ORDERING PARTS PLEASE SPECIFY YOUR MODEL NUMBER

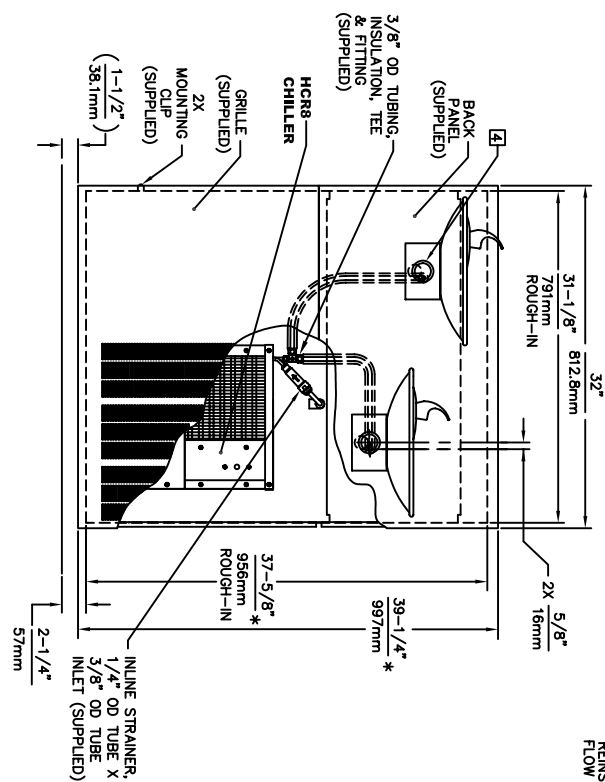
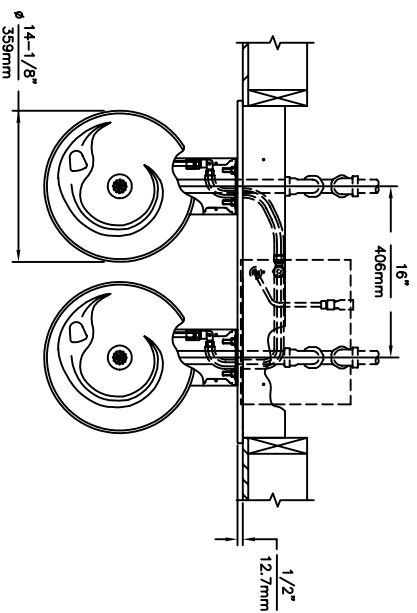

REMOVE VALVE FROM PUSH BUTTON TO INSTALL WASTE ELBOW ONTO BOWL. AFTER WASTE ELBOW IS INSTALLED, REINSTALL VALVE & ADJUST FLOW

- NOTES:**
1. HOLD ROUGH-IN DIMENSIONS $\pm 1/8"$ (3.2mm).
 2. WHEN INSTALLING THIS UNIT, LOCAL, STATE, OR FEDERAL CODES SHOULD BE ADHERED TO. FOR DIMENSIONS (LOCATIONS), WASTE AND SUPPLY REQUIREMENTS OTHER THAN SHOWN, DIMENSIONS MARKED (*) MUST BE ADJUSTED ACCORDINGLY.
 3. INSTALLER MUST PROVIDE TRAP FOR PROPER INSTALLATION.
 4. REFER TO 5874SS OPERATION AND MAINTENANCE MANUAL FOR PUSH BUTTON AND VALVE INSTALLATION/MAINTENANCE INSTRUCTIONS.
 5. REFER TO MTRFR LG INSTALLATION DRAWING FOR ROUGH-IN DIMENSIONS.
 6. INSERT 5/16" - 18 PANELE INSERTS FROM OPPOSITE SIDE AT LOCATIONS SHOWN BY EXPANDED HOLE LOCATIONS. USE OPPOSITE SIDE FOR FOUNTAIN ON THE RIGHT AND THE HI FOUNTAIN ON THE LEFT. USE OPPOSITE HOLES FOR HI ON RIGHT AND LOW ON LEFT.
 7. HOLE COMBINATION SHOWN BELOW IS FOR USE WITH LOW FOUNTAIN ON THE LEFT AND HIGH FOUNTAIN ON THE RIGHT. USE OPPOSITE HOLES FOR HIGH ON RIGHT AND LOW ON LEFT.
 8. TO CHANGE FOUNTAIN MFG. SCREW LOCATIONS, FIRST REMOVE SCREWS AND THEN SQUEEZE CLIPS ON NUT RETAINER TO POP OUT. SNAP INTO NEW POSITIONS AND RE-ASSEMBLE SCREWS.
 9. IMPORTANT: A L.H. LOW (OPTIONAL) CONFIGURATION WILL REQUIRE ADJUSTED DIMENSIONS AND THE DIMENSIONS SHOWN (*) MUST BE REVERSED.
 10. ALIGN HOLES IN CHILLER SUPPORT TRAY WITH HOLES IN FRAME AND FASTEN WITH #10 SHEET METAL SCREWS.

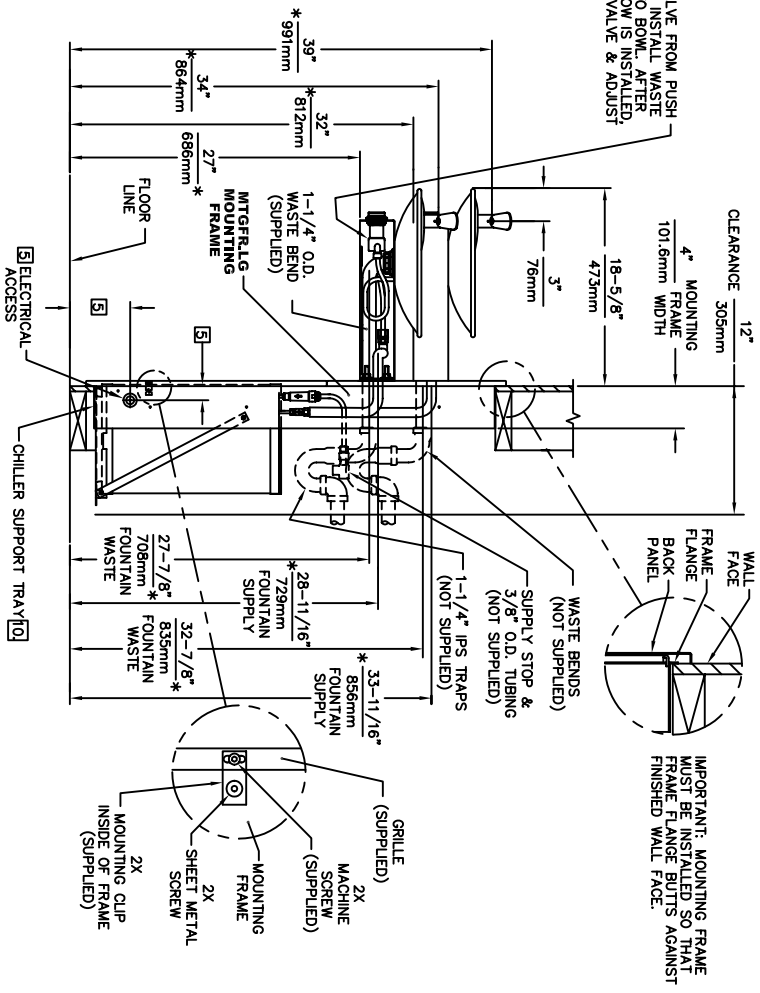

IMPORTANT: MOUNTING FRAME MUST BE INSTALLED SO THAT FRAME FLANGE BUTTS AGAINST FINISHED WALL FACE.

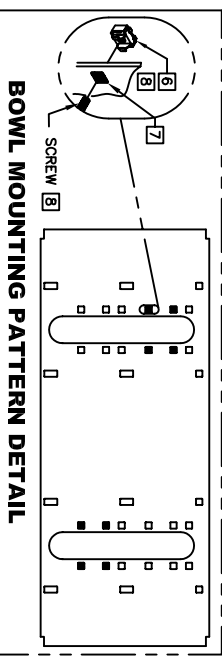

Haws

1455 KLEPPE LANE
SPARKS, NEVADA 89431
(775) 359-4712 FAX (775) 359-7424
EMAIL: HAWS@HAWSCO.COM
WEBSITE: WWW.HAWSCO.COM

MODEL(S)
H1011.8/H1011.8HPS

DRINKING FOUNTAIN

SCALE: 1/16"

DRAWING TYPE: INSTALLATION

SIZE: A

SHEET: 1 OF 1

EQ. NO. REVISED PERBY:	MODELS(S)
DRAWING NO. ECK: 4483 HM	DATE: 07/07
CHKD: H1011.8/H1011.8HPS	DATE: 07/07
APPROVED: [Signature]	SCALE: 1/16"
PART NUMBER: 0002080249.D	DRAWING NO.: 13135A00
REV: 1	SHEET: 1 OF 1