



INSTALLATION, OPERATION & MAINTENANCE INSTRUCTIONS

1455 Kleppe Lane ♦ Sparks, NV 89431-6467 ♦ (775) 359-4712 ♦ Fax (775) 359-7424
E-mail: haws@hawsco.com ♦ website: www.hawsco.com

No. 2080194(9)

Model 8605WC Barrier Free Emergency Shower & Eye/Face Wash Booth

NOTE TO INSTALLER: Please leave this information with the Maintenance Department.

LIMITED WARRANTY

HAWS® warrants that all of its products are guaranteed against defective material or poor workmanship for a period of **one year from date of shipment**. HAWS liability under this warranty shall be discharged by furnishing without charge F.O.B. HAWS Factory any goods, or part thereof, which shall appear to the Company upon inspection to be of defective material or not of first class workmanship, provided that claim is made in writing to company within a reasonable period after receipt of the product. Where claims for defects are made, the defective part or parts shall be delivered to the Company, prepaid, for inspection. HAWS will not be liable for the cost of repairs, alterations or replacements, or for any expense connected therewith made by the owner or his agents, except upon written authority from HAWS, Sparks, Nevada. HAWS will not be liable for any damages caused by defective materials or poor workmanship, except for replacements, as provided above. Buyer agrees that Haws has made no other warranties either expressed or implied in addition to those above stated, except that of title with respect to any of the products or equipment sold hereunder and that HAWS shall not be liable for general, special, or consequential damages claimed to arise under the contract of sale.

The emergency equipment manufactured by HAWS is warranted to function if installation and maintenance instructions provided are adhered to. The units also must be used for the purpose, which they were intended. This product is intended to supplement first-aid treatment. Due to widely varying conditions HAWS cannot guarantee that the use of this emergency equipment will prevent serious injury or the aggravation of existing or prior injuries.

NO OTHER WARRANTIES EXPRESSED OR IMPLIED ARE AUTHORIZED, PROVIDED OR GIVEN BY HAWS.

SHOULD YOU EXPERIENCE DIFFICULTY WITH THE INSTALLATION OF THIS MODEL, PLEASE CALL:

1-800-766-5612

FOR PARTS CALL:

1-800-758-9378

**(U.S.A. AND CANADA ONLY) MONDAY-THURSDAY: 6:00 A.M. – 4:00 P.M. PST
FRIDAY: 6:00 A.M – 1:00 P.M. PST**

LOCATION OF UNIT: The Model 8605WC Barrier Free Emergency Shower & Eye/Face Wash Booth should be installed in close proximity to potential accident areas. It should be clearly identified free from obstructions and easy to access.

SUPPLY LINE: The minimum recommended line size is 1" IPS with 30-90 psi (2-6 ATM) flowing pressure. Where sediment or mineral content is a problem, an inlet filter is recommended.

PLUMBING CONNECTIONS: Inlet supply is female 1" IPS. Waste outlet is 3" IC (Inside caulk).

TROUBLESHOOTING	
PROBLEM	REPAIR CHECKLIST
1. No flow.	1. Check the main shut-off valve.
2. Insufficient water flow.	2. Verify minimum 30 psi (2 ATM) flowing supply line pressure.
3. Insufficient water flow. On eyewash, however, shower is sufficient.	3. a. Probable clogging of flow control due to inadequate line flushing. Unscrew eye/face wash head and remove the four screws to disassemble the head. Clean flow control and reassemble head. See SP65 Installation Drawing for details.
4. Insufficient water flow at the showerhead, however, eyewash is sufficient.	4. Probable clogging of flow control inside showerhead. Unscrew showerhead off of elbow and clean rubber flow control.
5. Eyewash stream does not meet desired eye level.	5. Possible blocked flow control, see above solution. Possible non-leveled eyewash assembly.
6. Water does not drain properly.	6. Check the main waste line of your building to see if it does handle the capacity required for the entire drainage system.

For more information on Haws products, see our website: www.hawSCO.com

ITEM	DESCRIPTION
1	SP65 EYE/FACE WASH ASSEMBLY
2	SP229 VALVE ASSEMBLY
3	SP202 PULL ROD
4	SP178 SHOWER/EYEWASH SIGN
5	SP170 TEST TAG
6	SP178LG SHOWER/EYEWASH LABEL
7	SP829 SHOWER HEAD
8	SHOWER VALVE ASSEMBLY

PARTS BREAKDOWN

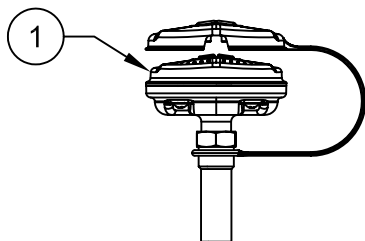
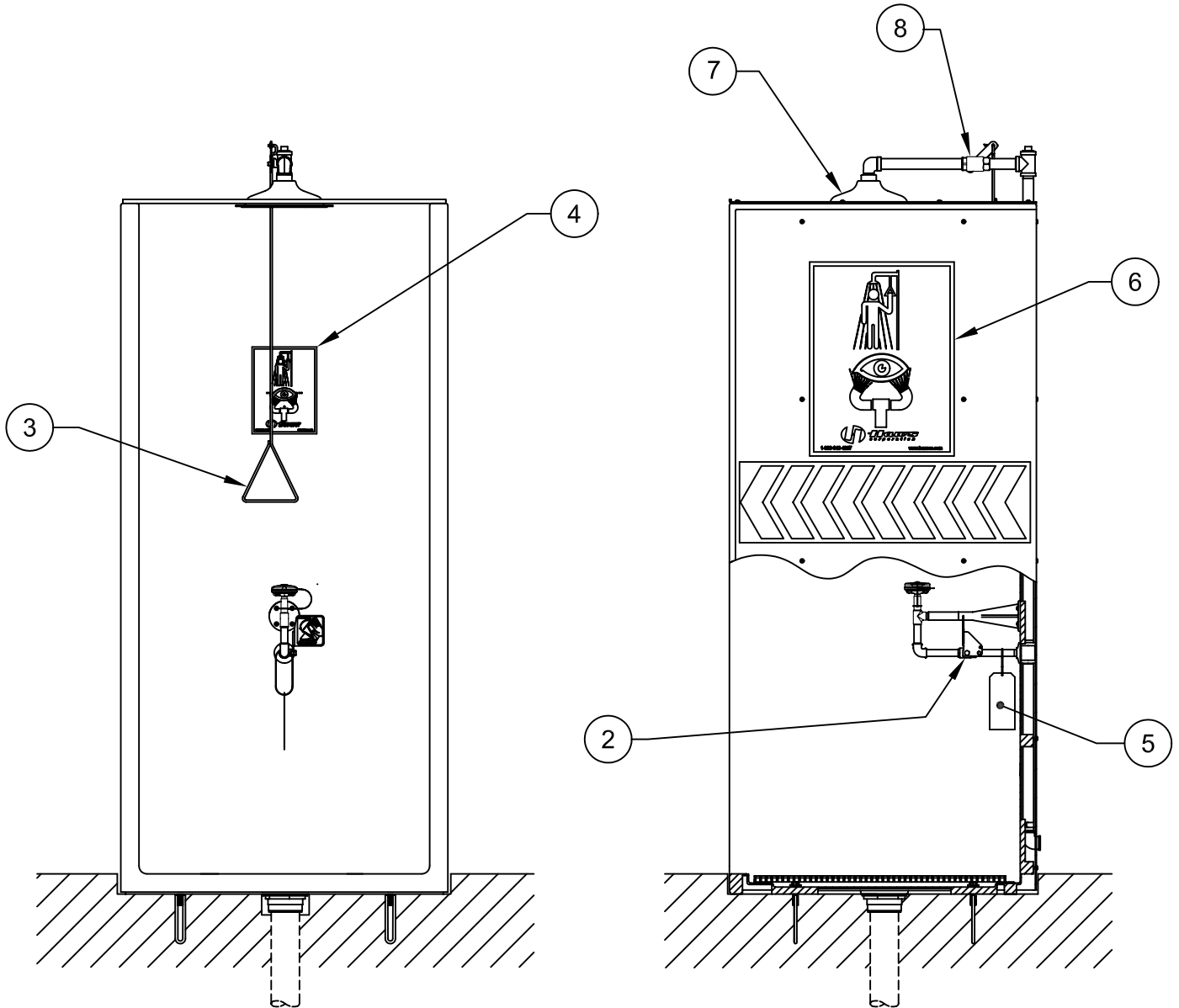

SP65 EYE/FACE WASH ASSEMBLY

WHEN ORDERING PARTS PLEASE SPECIFY YOUR MODEL NUMBER



1455 KLEPPE LANE
SPARKS, NEVADA 89431
(775) 359-4712 FAX (775) 359-7424
E-MAIL: HAWS@HAWS.CO.COM
WEBSITE: WWW.HAWS.CO.COM

DRAWN BY: RTM	DATE: 08/16/01	CHECK BY:	APPVD BY:	SCALE: 1/10
TITLE: 8605WC EMERGENCY SHOWER			PART NUMBER: 0002080194	
DRAWING TYPE: PARTS BREAKDOWN			DRAWING NUMBER: 15124C00	REV: 9

REV	DESCRIPTION	ECN	DATE	BY/APVD
9	UPDATED PER ECN	4367	12/3/09	IR
REVISIONS				

INCH [13mm].

2. TO COMPLY WITH ANSI Z358.1-2009 FOR EMERGENCY EYEWASH OR EYEFACE WASH AND SHOWER EQUIPMENT:
 - UNIT SHALL BE INSTALLED IN ACCORDANCE WITH MANUFACTURER'S INSTRUCTIONS AND ACCEPTABLE PLUMBING PRACTICES.
 - EYEWASH OR EYEFACE WASH SHALL BE POSITIONED WITH NOZZLES NOT LESS THEN 83.8 CM (33 IN.) AND NO GREATER THAN 114.3 CM (45 IN.) FROM SURFACE ON WHICH USER STANDS AND 15.3 CM (6 IN.) MINIMUM FROM WALL OR NEAREST OBSTRUCTION.
 - SHOWER SHALL BE POSITIONED SO THAT SHOWER HEAD IS NOT LESS THAN 208.3 CM (82 IN.) NOR MORE THAN 243.3 CM (96 IN.) FROM SURFACE ON WHICH USER STANDS.
 - SHOWER SPRAY PATTERN SHALL HAVE A MINIMUM DIAMETER OF 50.8 CM (20 IN.) AT 152.4 CM (60 IN.) ABOVE SURFACE ON WHICH USER STANDS, AND CENTER OF SPRAY PATTERN SHALL BE LOCATED AT LEAST 40.6 CM (16 IN.) FROM ANY OBSTRUCTION.
3. FLOW RATE FOR EYEFACE WASH IS 3.7 GPM AND 1.32 GPM FOR EYEWASH CONVERSION. BOTH EXCEED ANSI Z358.1-2009 STANDARD.