



INSTALLATION, OPERATION & MAINTENANCE INSTRUCTIONS

1455 Kleppe Lane ♦ Sparks, NV 89431-6467 ♦ (775) 359-4712 ♦ Fax (775) 359-7424
E-mail: haws@hawsco.com ♦ website: www.hawsco.com

No. 2080064(10)

Model 7612 Eye/Face Wash

NOTE TO INSTALLER: Please leave this information with the Maintenance Department.

LIMITED WARRANTY

HAWS® warrants that all of its products are guaranteed against defective material or poor workmanship for a period of **one year from date of shipment**. HAWS liability under this warranty shall be discharged by furnishing without charge F.O.B. HAWS Factory any goods, or part thereof, which shall appear to the Company upon inspection to be of defective material or not of first class workmanship, provided that claim is made in writing to company within a reasonable period after receipt of the product. Where claims for defects are made, the defective part or parts shall be delivered to the Company, prepaid, for inspection. HAWS will not be liable for the cost of repairs, alterations or replacements, or for any expense connected therewith made by the owner or his agents, except upon written authority from HAWS, Sparks, Nevada. HAWS will not be liable for any damages caused by defective materials or poor workmanship, except for replacements, as provided above. Buyer agrees that Haws has made no other warranties either expressed or implied in addition to those above stated, except that of title with respect to any of the products or equipment sold hereunder and that HAWS shall not be liable for general, special, or consequential damages claimed to arise under the contract of sale.

The emergency equipment manufactured by HAWS is warranted to function if installation and maintenance instructions provided are adhered to. The units also must be used for the purpose, which they were intended. This product is intended to supplement first-aid treatment. Due to widely varying conditions HAWS cannot guarantee that the use of this emergency equipment will prevent serious injury or the aggravation of existing or prior injuries.

NO OTHER WARRANTIES EXPRESSED OR IMPLIED ARE AUTHORIZED, PROVIDED OR GIVEN BY HAWS.

SHOULD YOU EXPERIENCE DIFFICULTY WITH THE INSTALLATION OF THIS MODEL PLEASE CALL:

TECHNICAL SUPPORT: 1-800-766-5612

FOR CUSTOMER SERVICE: 1-888-640-4297

LOCATION OF UNIT: The Model 7612 Eye/face wash should be installed in close proximity to potential accident areas. It should be clearly identified free from obstructions and easy to access.

SUPPLY LINE: The minimum recommended line size is 1/2" IPS with 30-90 psi (2-6 ATM) pressure. Where sediment or mineral content is a problem, an inlet filter is recommended.

PLUMBING CONNECTIONS: Inlet supply is 1/2". Waste outlet is 1-1/4" NPT.

TROUBLESHOOTING

PROBLEM	REPAIR CHECKLIST
1. No flow.	1. Check the main shut-off valve.
2. Insufficient water flow.	2. a. Verify minimum 30 psi flowing supply line pressure. b. Probable clogging of flow control due to inadequate line flushing. Unscrew eye/face wash head and remove the four screws to disassemble head. Clean flow control and reassemble head.
3. Eye/face wash streams do not meet desired eye level.	3. a. Possible blocked flow control, see above solution. b. Possible non-leveled eye/face wash assembly.
4. Water does not drain properly.	4. Check the main wasteline of your building to see if it does handle the capacity required for the entire drainage system.

For more information about Haws products, see our website: www.hawesco.com

PARTS BREAKDOWN

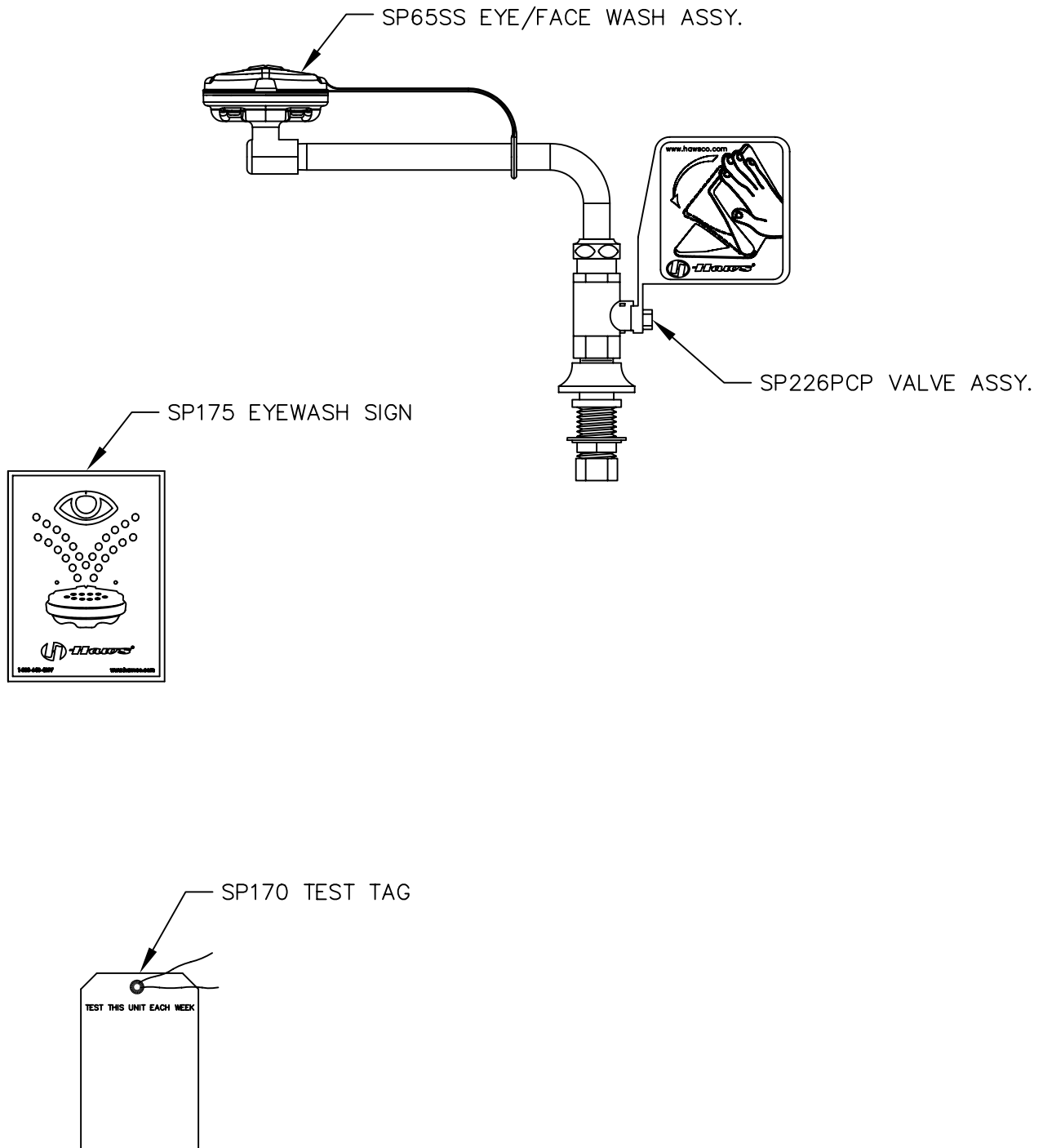

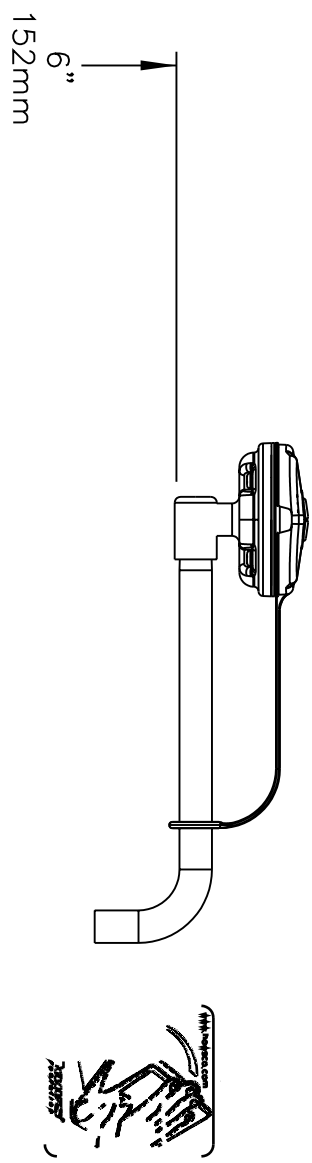

		Haws [®]		1455 KLEPPE LANE SPARKS, NEVADA 89431 (775) 359-4712 FAX (775) 359-7424 E-MAIL: HAWS@HAWSCO.COM WEBSITE: WWW.HAWSCO.COM	
				ECN NO: _____ ECN: 4351 REVISOR: IR	MODEL(S) 7612
DRAWN: CLF APPROVED: _____	DATE: 3/02/93 DATE: _____	CHKD: _____ DATE: _____	DRAWING NO.: 11456C00 SCALE: 1/2 DRAWING TYPE: PARTS BREAKDOWN	REV. 10 SHEET 1 OF 1	

WHEN ORDERING PARTS PLEASE SPECIFY YOUR MODEL NUMBER



NOTES:

1. THE ANSI Z358.1-2009 STANDARD SPECIFIES EYEWASH NOZZLE HEIGHTS TO BE 83.8cm (33 IN.) TO 114.3cm (45 IN.) ABOVE THE FLOOR. CENTERLINE OF EYEWASH HEADS MUST BE 15.2cm (6 IN.) MIN. AWAY FROM WALL OR NEAREST OBSTRUCTION.
2. DIMENSIONS MAY VARY ±1/2" [12.7mm]

				1455 KLEPPLE LANE SPARKS, NEVADA 89431 (775) 359-4712 FAX (775) 359-7424 EMAIL: HAWS@HAWSCO.COM WEBSITE: WWW.HAWSCO.COM	
EON NO. REVISED PER BY:	MODEL(S)	POLISH CHROME PLATE DECK MTD. E/F WASH			
DRAWING NO. 4381	7612	PART NUMBER: 0002080064.D			
DATE: 10/27/11	CHKD:	DRAWING NO.: 09193A00			
APPROVED: DATE:	SCALE: 1/4"	DRAWING TYPE: INSTALLATION			
		SIZE: A SHEET: 1 OF 1			