



**INSTALLATION, OPERATION
&
MAINTENANCE INSTRUCTIONS**

1455 Kleppe Lane ♦ Sparks, NV 89431-6467 ♦ (775) 359-4712 ♦ Fax (775) 359-7424
E-mail: haws@hawsco.com ♦ website: www.hawsco.com

No. 2080059(11)

**Model 7500EB
Portable Eyewash with Heater**

NOTE TO INSTALLER: Please leave this information with the Maintenance Department.

LIMITED WARRANTY

HAWS® warrants that all of its products are guaranteed against defective material or poor workmanship for a period of **one year from date of shipment**. HAWS liability under this warranty shall be discharged by furnishing without charge F.O.B. HAWS Factory any goods, or part thereof, which shall appear to the Company upon inspection to be of defective material or not of first class workmanship, provided that claim is made in writing to company within a reasonable period after receipt of the product. Where claims for defects are made, the defective part or parts shall be delivered to the Company, prepaid, for inspection. HAWS will not be liable for the cost of repairs, alterations or replacements, or for any expense connected therewith made by the owner or his agents, except upon written authority from HAWS, Sparks, Nevada. HAWS will not be liable for any damages caused by defective materials or poor workmanship, except for replacements, as provided above. Buyer agrees that Haws has made no other warranties either expressed or implied in addition to those above stated, except that of title with respect to any of the products or equipment sold hereunder and that HAWS shall not be liable for general, special, or consequential damages claimed to arise under the contract of sale.

The emergency equipment manufactured by HAWS is warranted to function if installation and maintenance instructions provided are adhered to. The units also must be used for the purpose, which they were intended. This product is intended to supplement first-aid treatment. Due to widely varying conditions HAWS cannot guarantee that the use of this emergency equipment will prevent serious injury or the aggravation of existing or prior injuries.

**NO OTHER WARRANTIES EXPRESSED OR IMPLIED ARE AUTHORIZED,
PROVIDED OR GIVEN BY HAWS.**

**SHOULD YOU EXPERIENCE DIFFICULTY WITH THE INSTALLATION OF THIS
MODEL PLEASE CALL:**

TECHNICAL SUPPORT: 1-800-766-5612

FOR CUSTOMER SERVICE: 1-888-640-4297

RECOMMENDED TOOLS: Three 1/4" diameter anchors suitable for supporting filled eye wash (approximately 140 pounds) and tools needed to install these anchors.

LOCATION OF UNIT: The Model 7500EB Portable Eyewash should be installed in close proximity of potential accident areas. It should be clearly identified, free from obstructions and easily accessible. May be wall or shelf mounted. **NOTE: Personal wash units shall be protected from freezing and shall not be exposed to ambient temperatures exceeding 38°C (100°F).**

ELECTRICAL CONNECTIONS: The Model 7500EB requires a 120 VAC, three-prong outlet PROTECTED BY GROUND FAULT INTERRUPTER. It is provided with a heavy-duty 6 foot power cord and draws up to 9 amps current.

INSTALLATION INSTRUCTIONS

STEP 1: Wall mount with "J" Bracket supplied (see Installation Drawing). (1/4" mounting hardware not supplied), or mount on shelf. Make sure portable eyewash unit is level from front to back and left to right before securing bracket to wall. Eyewash nozzles should be between 33 inches (83.8 cm) and 45 inches (114.3 cm) above the floor when eye wash arm is in the active (lowered) position (See Installation Drawing Page 7 of 7).

IMPORTANT:

Filled eyewash unit is heavy (approximately 140 pounds). Wall bracket anchors, (Quantity-3, not supplied), or shelf must be strong enough to support the filled eyewash and the weight of a worker leaning on eyewash.

STEP 2: Install drain hose, if desired.

STEP 3: Fill up to fill line (make sure that no debris or contaminants of any kind are present in the flushing fluid). Make sure unit is level from front to back and left to right. If installed as indicated, eyewash unit will provide 15-minute duration of flow.

CAUTION – MAKE SURE EYEWASH UNIT IS FILLED WITH FLUSHING FLUID (UP TO FILL LINE) BEFORE CONNECTING HEATER TO POWER SOURCE.

STEP 4: Connect heater to power source (see Electrical Connections above).

STEP 5: Take proper precautions to help prevent the growth of potentially harmful bacteria in eyewash tanks. (Refer to Maintenance Instructions).

STEP 6: To remove insulated jacket: Pull eyewash flap completely open. Work jacket off bottom of tank first, then off top of tank. To replace jacket, hook jacket over top of tank first then work jacket over tank bottom from back to front.

OPERATING INSTRUCTIONS

Instruct all employees in the use of this Emergency Eyewash. Personnel should be assigned to check eyewash liquid level daily.

- STEP 1:** Lead patient to nearest eyewash station. Seconds can make all the difference in preventing serious eye injury.
- STEP 2:** Pull yellow eyewash strap firmly until all the Velcro has disengaged. Eyewash arm will drop to bowl to activate eyewash.
- STEP 3:** Lower head until eyes enter eyewash stream. Use thumbs and forefingers to hold eyelids open. Flush for 15 minutes.
- STEP 4:** Seek qualified medical attention immediately.

MAINTENANCE INSTRUCTIONS

NOTE: Customer must provide an inspection tag and maintain a record of inspection dates and type of maintenance performed (i.e. adding bacteriostatic preservative, etc.).

- STEP 1:** Self contained eyewash equipment shall be visually checked to determine if flushing fluid needs to be changed or supplemented.

Frequency of inspection: Depending on environmental conditions, visual inspections should be performed on either a daily, weekly or monthly basis as some water loss will occur due to natural evaporation process.

- STEP 2:** Take proper precautions to help prevent the growth of potentially harmful bacteria in eyewash tanks. We recommend **either** of the following procedures:
 - A.** Procedure 1: Use suitable Bacteriostatic Preservative to help prevent the growth of bacteria in eyewash tank. Eyewash tank should be drained, flushed and refilled with clean potable water and Bacteriostatic Preservative as directed by the preservative's manufacturer.
 - B.** Procedure 2: Drain, flush and refill portable units with clean potable water at least once every week. Thoroughly cleanse tank at least once every month.

NOTE: Acanthamoeba survive mild chlorination and are commonly found in tap water. Bacteriostatic Preservative will prevent the growth of Acanthamoeba. Hot water, 158° F (70° C) or hotter will destroy Acanthamoeba but must be allowed to cool prior to use in eyewash units.

TROUBLESHOOTING	
PROBLEM	REPAIR CHECKLIST
1. No flow.	1. a. Tank empty. Refill tank. b. Obstruction in line or fitting. Clear obstruction.
2. Poor flow from eyewash head(s).	2. a. Tighten head assembly. b. Check for obstructions. If necessary, remove eyewash head(s), clean and reassemble. To reassemble head, place cap screw through head and thread into head anchor two or three turns. Tilt head assembly and work anchor legs into eyewash armholes. Tighten assembly. Check for leaks.
3. Water leak between joints or fittings.	3. a. Pull hose off fitting. Smooth raised plastic edge on center of fitting. Return hose and hose clamp to original position. b. Tighten hose clamp(s) with pliers
4. Eyewash flows for less than 15 minutes.	4. a. Fill water level in eyewash tank even with water fill line (indicated on front of unit).
5. Heater doesn't turn on.	5. a. Not plugged in or no power to plug. Check GFI and circuit breaker. b. See "Red light on" Section 10a.
6. Heater doesn't reset.	6. a. Water temperature is outside of heater operating temperature range. Heater settings are: Non-adjustable thermostat preset to switch at 70°F ± 5°F (21°C ± -15°C) (on rising temperature). Also, non-adjustable hi-limit thermostat with manual reset button preset to switch at 90° F ± 5° F (32°C ± -15°C) (on rising temperature). b. If ambient temperature is high and doesn't allow the water temperature to drop below 65°F (18°C) heater may not reset. If heater must be operable under these conditions, then, provisions should be made to accelerate the cooling process (i.e. adding ice to contents, etc.). Avoid contaminating water during this process.
7. Green light won't go on.	7. a. Not plugged in or no power to plug. Check GFI and circuit breaker. b. If red light is on, skip to "Red Light On", Section 10. c. Yellow light or heater cycles ON/OFF. Green light burned out. Replace green lamp.
8. Yellow light won't go on.	8. a. If red light is on, skip to "Red Light On", Section 10. b. When the eyewash temperature is above 60°F (16°C) the heater and Heater Indicator Light (Yellow) may not turn on. c. Yellow light is burned out if the heater turns on but the light does not. Replace yellow light.
9. Yellow light is on all the time.	9. a. Heater not working. Contact Haws Representative for service or return authorization.

TROUBLESHOOTING (Continued...)	
PROBLEM	REPAIR CHECKLIST
<p>10. Red light on.</p> <div style="border: 1px solid black; padding: 5px; margin: 10px auto; width: fit-content;"> <p>NOTE: WHEN RED LIGHT IS ON, HEATER IS DISABLED AND UNIT MAY FREEZE.</p> </div>	<p>10. a. When internal water temperature reaches 90°F ± 5°F (32°C ± 15°C), the Manual Reset High Limit Thermostat trips. Push Reset Button located on heater junction box at lower right corner of unit. Unit cannot be manually reset until internal temperature drops below 65°F (18°C).</p> <p>b. IMPORTANT! If red light comes on when outside temperatures are cold, unit is overheating. Either there is no water in unit or the Primary Thermostat has failed. Contact Haws Representative for service or return authorization. If the unit was empty, simply fill and push reset button to resume operation.</p>
<p>11. Excessive water loss</p>	<p>11. a. Check unit for leaks. Some loss due to evaporation is normal.</p>

ITEM	DESCRIPTION
1	SP19 EYEWASH HEAD ASSY
2	BRACKET P/N 0001217418
3	SP131 CAP
4	9125 JACKET
5	HEATER P/N 0002986400

PARTS BREAKDOWN

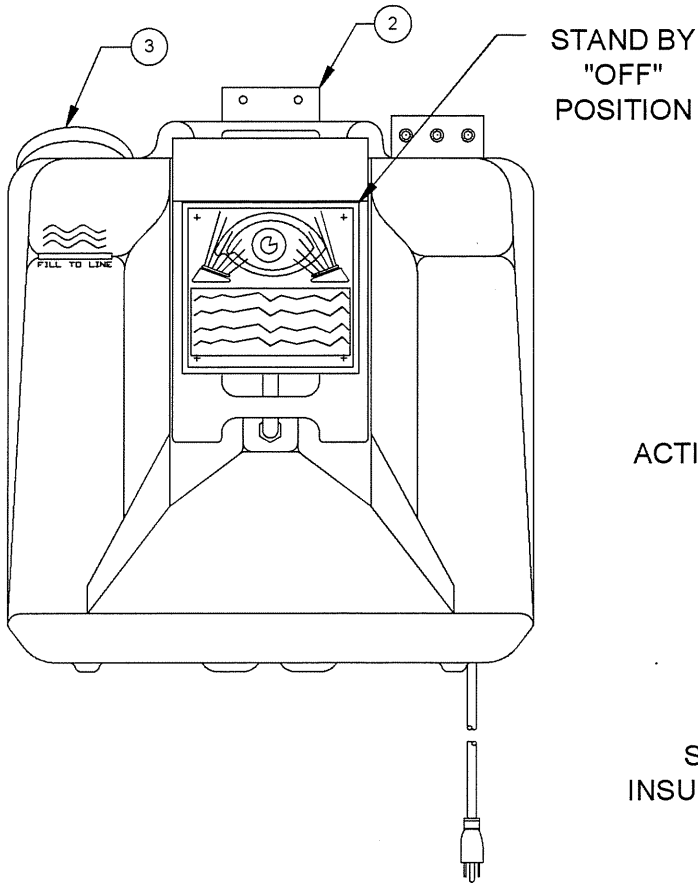

ACTIVE "ON" POSITION

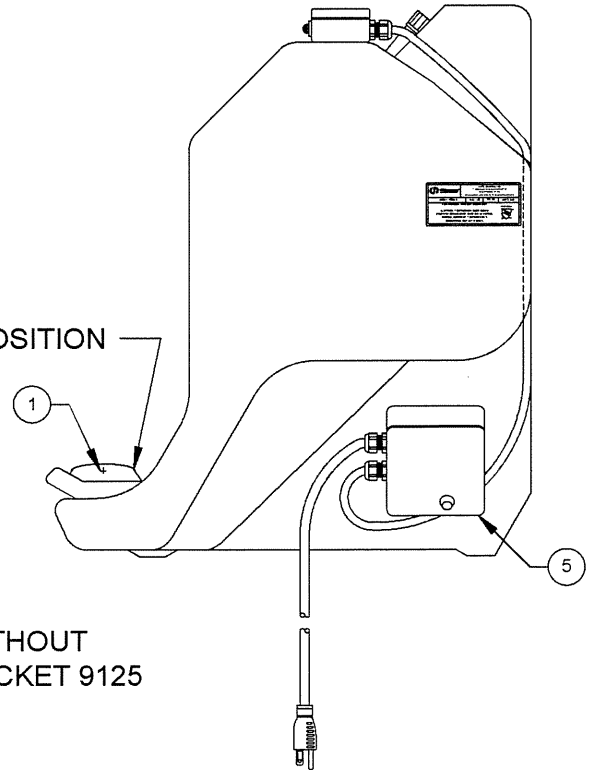

SHOWN WITHOUT
INSULATING JACKET 9125

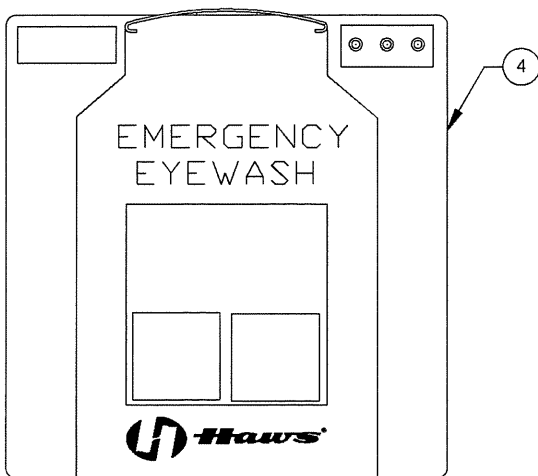

7500EB ASSEMBLED
WITH 9125 JACKET

WHEN ORDERING PARTS PLEASE SPECIFY MODEL NUMBER.

		1455 KLEPPE LANE SPARKS, NEVADA 89431 (775) 359-4712 FAX (755) 359-7424 E-MAIL: HAWS@HAWSO.COM WEBSITE: WWW.HAWSO.COM	
		ECN NO. REVISED PER BY ECN: 4744 HM-2	MODEL(S) 7500EB
DRAWN CLF	DATE 02/24/93	CHECKED [Signature]	DRAWING NO. 11455C00
APPROVED [Signature]	DATE	SCALE: 1:1	DRAWING TYPE: PARTS BREAKDOWN SIZE: A SHEET 1 OF 1

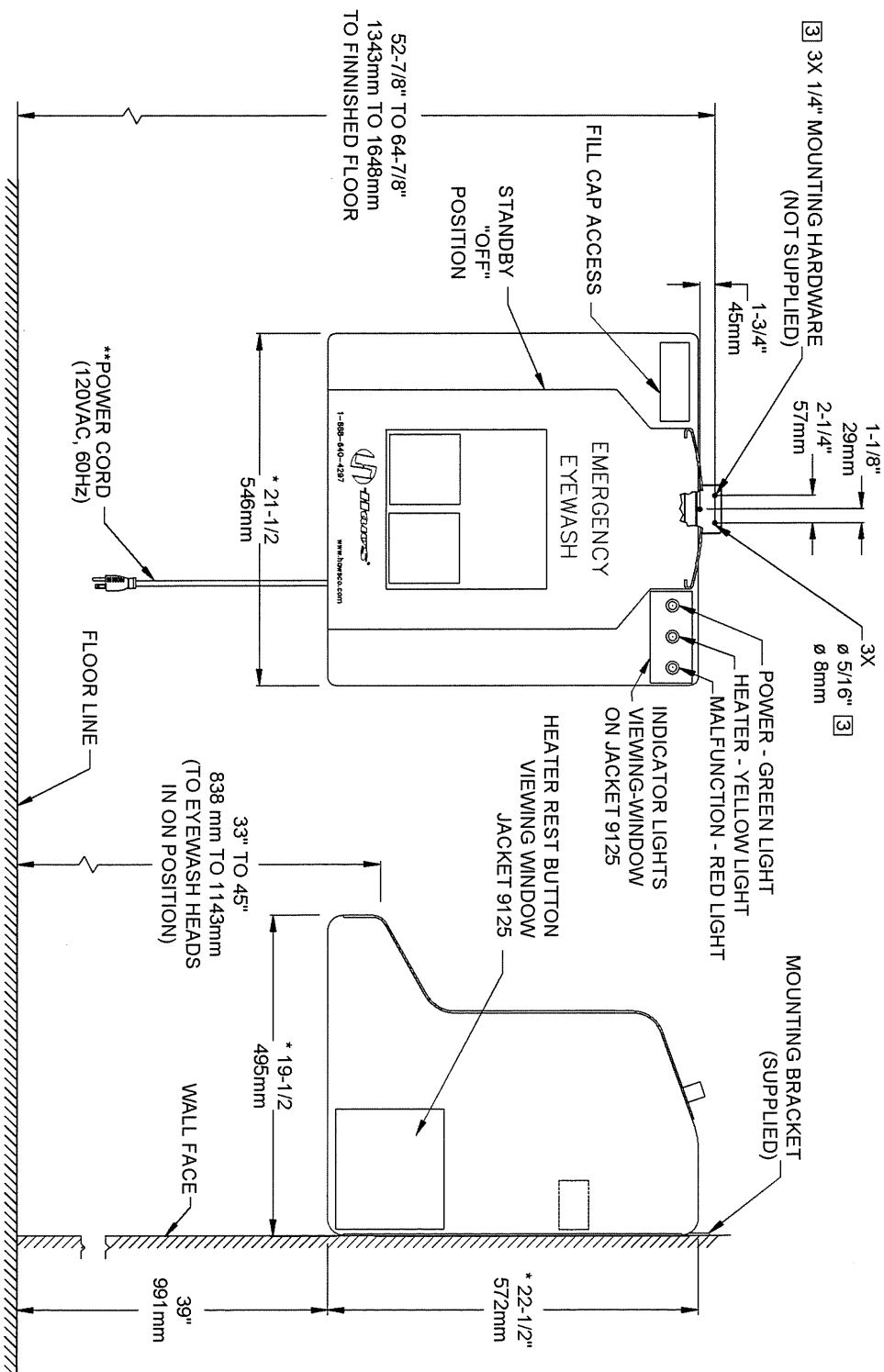

NOTES:

1. TO COMPLY WITH ANSI Z358.1-2009 FOR EMERGENCY EYEWASH OR EYEFACE WASH AND SHOWER EQUIPMENT:
 - UNIT SHALL BE INSTALLED IN ACCORDANCE WITH MANUFACTURER'S INSTRUCTIONS AND ACCEPTABLE PLUMBING PRACTICES
 - EYEWASH OR EYEFACE WASH SHALL BE POSITIONED WITH NOZZLES NOT LESS THAN 83.8 CM (33 IN.) AND NO GREATER THAN 114.2 CM (45 IN) FROM SURFACE WHICH USER STANDS AND (15.3 CM (6 IN.) MINIMUM FROM WALL OR NEAREST OBSTRUCTION.
2. UNIT MUST BE LEVEL FROM FRONT TO BACK AND SIDE TO SIDE
- 3 ALL THREE MOUNTING HOLES ON MOUNTING BRACKET MUST BE USED TO PROPERLY SECURE EYEWASH UNIT TO WALL.
4. **UNIT MUST BE FILLED WITH WATER BEFORE CONNECTING TO POWER SOURCE.**
5. PRIOR TO SERVICING/CLEANING: UNPLUG POWER CORD ON UNIT FROM POWER SOURCE AND REMOVE UNIT FROM MOUNTING BRACKET.
6. *DIMENSIONS MAY VARY ±1/2" (12.7mm)

©2012 Hawes Corporation - All Rights Reserved. HAWES® and other trademarks used in these materials are the exclusive property of Hawes Corporation.

		1455 KLEPPE LANE SPARKS, NEVADA 89431 (775) 359-4712 FAX (775) 359-7424 EMAIL: HAWES@HAWESCO.COM WEBSITE: WWW.HAWESCO.COM	
EON NO. REVISED PER: BY: _____	MODEL(S)	7500EB	PART NUMBER
DATE: _____	PORTABLE EYEWASH WITH HEATER		0002080059.D
APPROVED: _____	SCALE: 1:1	DRAWING TYPE: INSTALLATION	DRAWING NO. 07772A00
			REV 11
			SHEET 1 OF 1