



INSTALLATION, OPERATION & MAINTENANCE INSTRUCTIONS

1455 Kleppe Lane ♦ Sparks, NV 89431-6467 ♦ (775) 359-4712 ♦ Fax (775) 359-7424
E-mail: haws@hawsco.com ♦ website: www.hawsco.com

No. 2077370(12)

Model 3380FR/3380GFR/3380.6519FR Drinking Fountain

NOTE TO INSTALLER: Please leave this information with the Maintenance Department.

LIMITED WARRANTY

HAWS® warrants that all of its products are guaranteed against defective material or poor workmanship for a period of **one year from date of shipment**. HAWS liability under this warranty shall be discharged by furnishing without charge F.O.B. HAWS Factory any goods, or part thereof, which shall appear to the Company upon inspection to be of defective material or not of first class workmanship, provided that claim is made in writing to company within a reasonable period after receipt of the product. Where claims for defects are made, the defective part or parts shall be delivered to the Company, prepaid, for inspection. HAWS will not be liable for the cost of repairs, alterations or replacements, or for any expense connected therewith made by the owner or his agents, except upon written authority from HAWS, Sparks, Nevada. HAWS will not be liable for any damages caused by defective materials or poor workmanship, except for replacements, as provided above. Buyer agrees that Haws has made no other warranties either expressed or implied in addition to those above stated, except that of title with respect to any of the products or equipment sold hereunder and that HAWS shall not be liable for general, special, or consequential damages claimed to arise under the contract of sale. The drinking fountain manufactured by HAWS is warranted to function if installation and maintenance instructions provided are adhered to. The units also must be used for the purpose for which they were intended.

NO OTHER WARRANTIES EXPRESSED OR IMPLIED ARE AUTHORIZED, PROVIDED OR GIVEN BY HAWS.

SHOULD YOU EXPERIENCE DIFFICULTY WITH THE INSTALLATION OF THIS MODEL PLEASE CALL:

TECHNICAL SUPPORT: 1-800-766-5612

FOR CUSTOMER SERVICE: 1-888-640-4297

RECOMMENDED TOOLS: Hack saw, pipe joint sealant, screwdriver, level, 12" adjustable wrench, 10" pipe wrench, 5/64" hex key wrench, 9/16", 1/2", 7/16" socket wrench or open end wrench.

LOCATION OF UNIT: The Model 3380FR/3380GFR Drinking Fountain is a wheelchair accessible drinking water facility. The height dimensions shown, meet current ADA requirements. When installing this unit, local, state or federal codes should be adhered to. If height other than shown is required, then dimensions must be adjusted accordingly.

SUPPLY LINE: The minimum recommended line size is 1/2" IPS. Flowing pressure is 30-90 psi (2-6 ATM) for Models 3121FR and 3121.6280FR. Flowing pressure for Model 3121.6519FR is 45-90 psi (3-6 ATM). Where sediment or mineral content is a problem, an inlet filter is recommended.

PLUMBING CONNECTIONS: Supply inlet is 1/2" IPS male. Waste outlet is 1-1/2" O.D. tailpiece.

MAINTENANCE: Refer to 6518FR or 6519FR Operation and Maintenance Sheet for additional information.

INSTALLATION INSTRUCTIONS FOR 6519FR (SEE INSTALLATION DRAWING SHEET 2 OF 2)

1. Cut fountain waste line (1-1/2" Tiger Flex) as required and use PVC primer and cement to attach 6519FR waste and air gap assembly. (NOTE: Locate assembly at lowest possible point inside fountain).
2. Attach 2" long piece of 1-1/2" Tiger Flex Hose (supplied) to bottom of 6519FR waste and air gap assembly tee. Next attach adaptor with tailpiece (supplied with fountain), use PVC primer and cement on these connections.

| TROUBLESHOOTING 3380FR/3380GFR W/6518FR | |
|--|---|
| PROBLEM | REPAIR CHECKLIST |
| 1. Insufficient bubbler flow. | <ol style="list-style-type: none"> a. Check that inlet screwdriver stop valve is wide open (customer supplied). b. Verify minimum 30 psi flowing supply pressure. c. Adjust valve to increase flow. See 6518FR manual. |

| TROUBLESHOOTING 3380.6519FR | |
|------------------------------------|---|
| PROBLEM | REPAIR CHECKLIST |
| 1. Insufficient bubbler flow. | <ol style="list-style-type: none"> a. Check that inlet screwdriver stop valve is wide open (customer supplied). b. Verify minimum 45 psi flowing supply pressure. c. Adjust valve to increase flow. See 6519FR manual. |

PARTS BREAKDOWN

3380FR/3380GFR WITH 6518FR OR 6519FR

| ITEM | DESCRIPTION |
|------|--|
| 1 | VALVE 6518FR |
| 2 | STRAINER 0005624292 |
| 3 | BUBBLER HEAD 5705FR (STYLE A OR STYLE B) |
| 4 | PUSH BTN ASS'Y 5881PBA |
| 5 | VALVE 6519FR (OPTIONAL) |
| 6 | VALVE BOX 6625 (OPTIONAL) |
| 7 | DRIVER, NOZZLE .25 HEX 0002082253 |

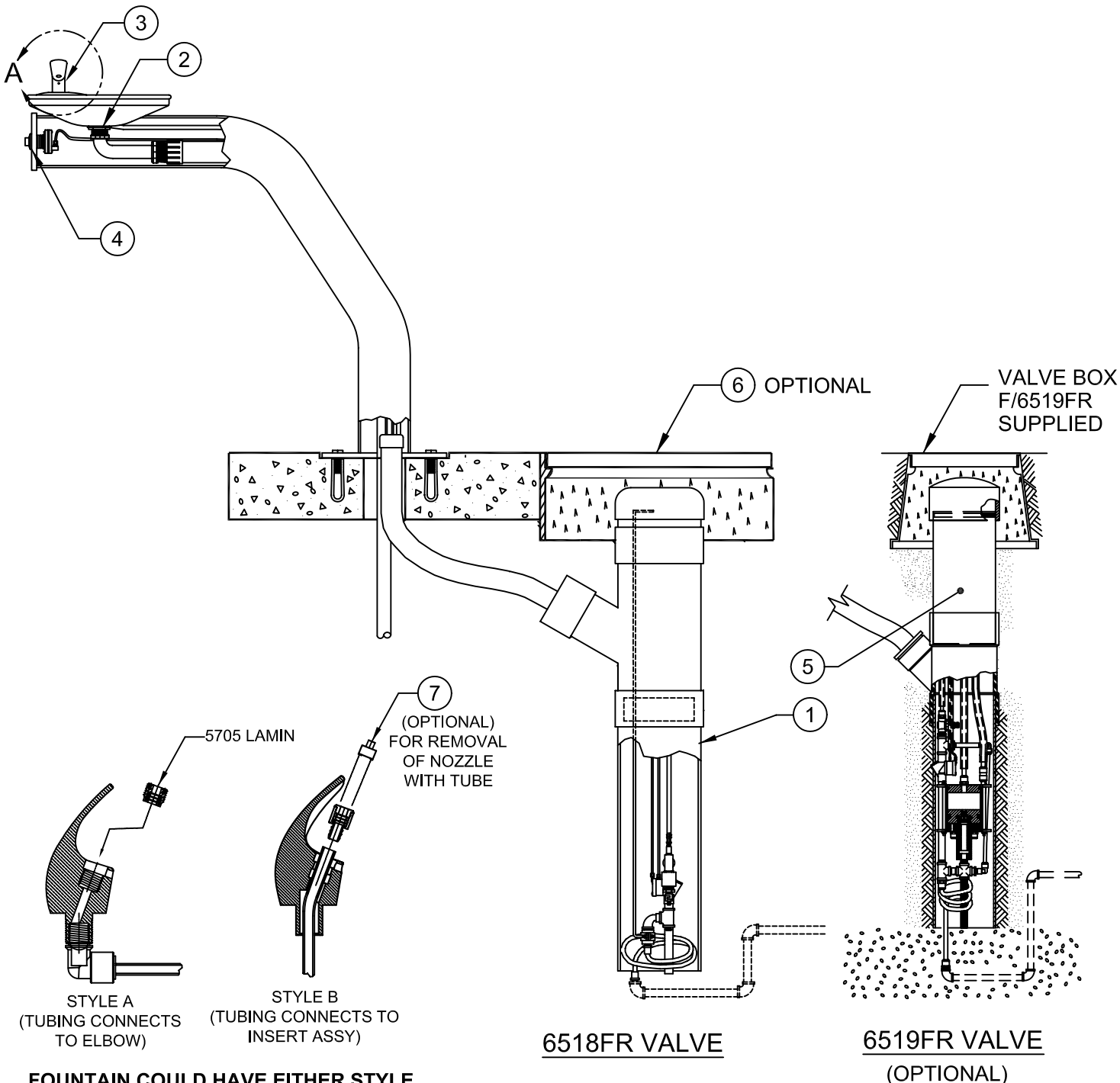

STYLE A (TUBING CONNECTS TO ELBOW)
 STYLE B (TUBING CONNECTS TO INSERT ASSY)

FOUNTAIN COULD HAVE EITHER STYLE

DETAIL A
 ROTATED 90° INTO VIEW

WHEN ORDERING PARTS PLEASE SPECIFY YOUR MODEL NUMBER



1455 KLEPPE LANE
 SPARKS, NEVADA 89431
 (775) 359-4712 FAX (775) 359-7424
 E-MAIL: HAWS@HAWS.CO.COM
 WEBSITE: WWW.HAWS.CO.COM

| | | | | |
|-----------------------------------|----------------|-----------|--------------------------|------------|
| DRAWN BY: D OLLOM | DATE: 11/25/95 | CHECK BY: | APPVD BY: | SCALE: 1:6 |
| TITLE: 3380FR/3380GFR/3380.6519FR | | | PART NUMBER: 0002077370 | |
| DRAWING TYPE: PARTS BREAKDOWN | | | DRAWING NUMBER: 12817C00 | REV: 12 |

3380FR/3380GFR WITH 6518FR

(SEE SHEET 2 OF 3 FOR 6519FR INSTALLATION)

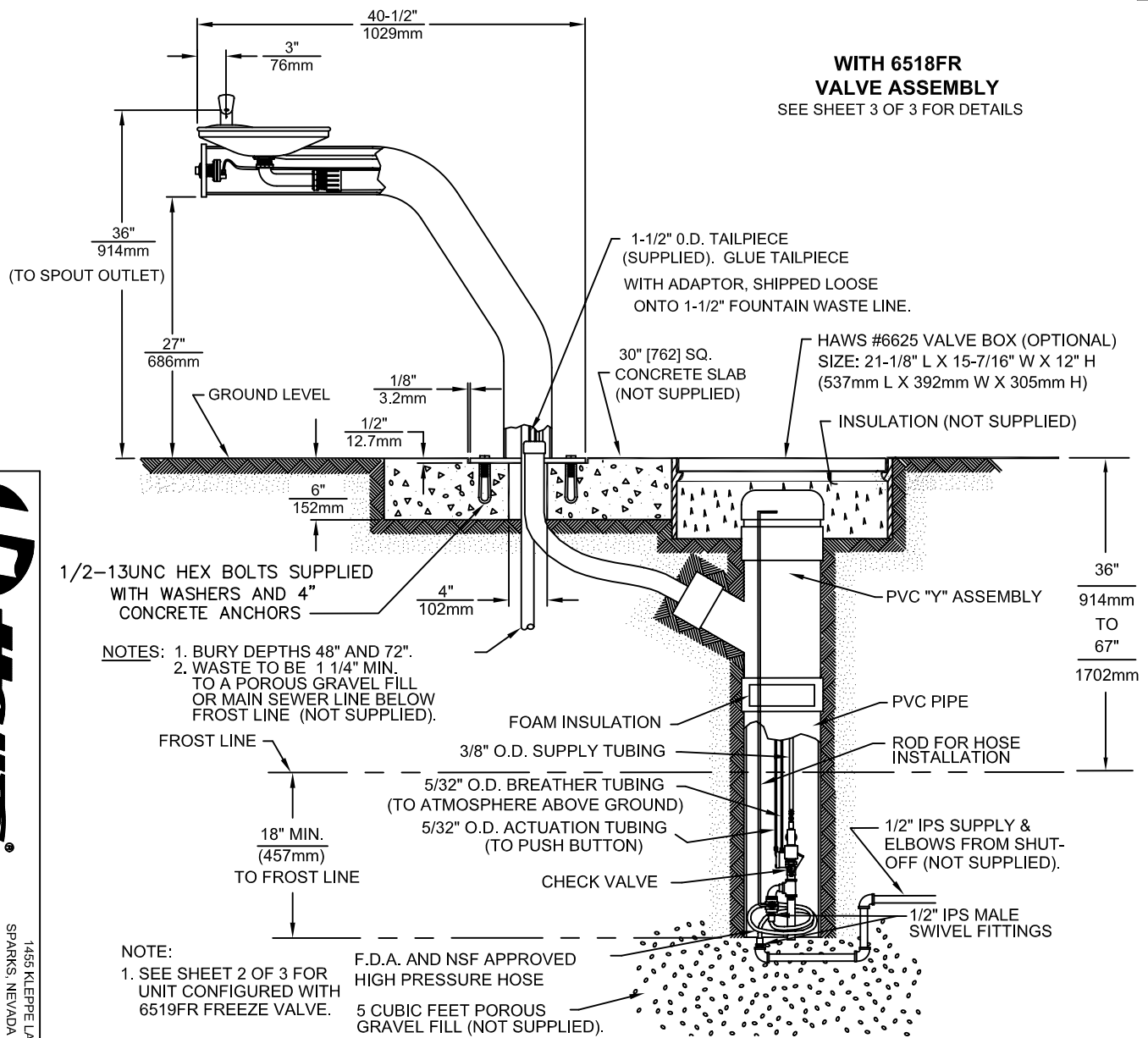
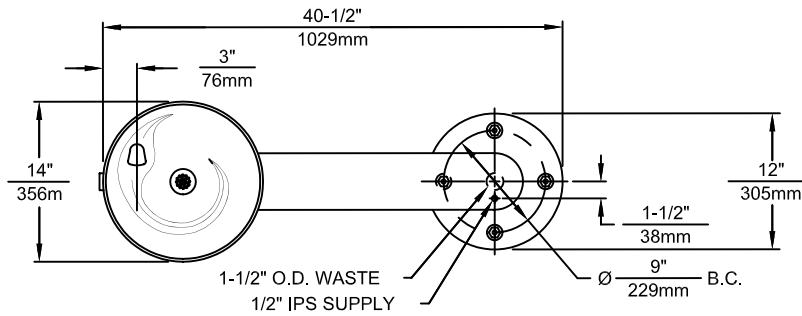

**WITH 6518FR
VALVE ASSEMBLY**
SEE SHEET 3 OF 3 FOR DETAILS

©2010 Haws Corporation - All Rights Reserved HAWES® and other trademarks used in these materials are the exclusive property of Haws Corporation.

| | | | |
|--|--|--|---|
| | EON NO.: 10289A00 MODEL(S): 3380FR/3380GFR/3380 6519FR INFO FAX DOC #: 2338037/2338043/23380651 APPROVER: [Signature] | DATE: 08/17/02 DATE: 08/17/02 DATE: 08/17/02 | HAWES CORPORATION 1455 KLEPPE LANE SPARKS, NEVADA 89431 (775) 359-4712 FAX (775) 359-7424 E-MAIL: HAWES@HAWESCO.COM WEBSITE: WWW.HAWESCO.COM |
| | EON NO.: 10289A00 MODEL(S): 3380FR/3380GFR/3380 6519FR INFO FAX DOC #: 2338037/2338043/23380651 | DATE: 08/17/02 DATE: 08/17/02 DATE: 08/17/02 | HAWES CORPORATION 1455 KLEPPE LANE SPARKS, NEVADA 89431 (775) 359-4712 FAX (775) 359-7424 E-MAIL: HAWES@HAWESCO.COM WEBSITE: WWW.HAWESCO.COM |
| | EON NO.: 10289A00 MODEL(S): 3380FR/3380GFR/3380 6519FR INFO FAX DOC #: 2338037/2338043/23380651 | DATE: 08/17/02 DATE: 08/17/02 DATE: 08/17/02 | HAWES CORPORATION 1455 KLEPPE LANE SPARKS, NEVADA 89431 (775) 359-4712 FAX (775) 359-7424 E-MAIL: HAWES@HAWESCO.COM WEBSITE: WWW.HAWESCO.COM |
| | EON NO.: 10289A00 MODEL(S): 3380FR/3380GFR/3380 6519FR INFO FAX DOC #: 2338037/2338043/23380651 | DATE: 08/17/02 DATE: 08/17/02 DATE: 08/17/02 | HAWES CORPORATION 1455 KLEPPE LANE SPARKS, NEVADA 89431 (775) 359-4712 FAX (775) 359-7424 E-MAIL: HAWES@HAWESCO.COM WEBSITE: WWW.HAWESCO.COM |

